



High-speed 1T 8051-based Flash MCU, 512 bytes SRAM, 8 Kbytes Flash, 128 bytes independent EEPROM, 12-bit ADC, Three 8+2-bit PWM Outputs, Three Timer/Counters, UART, STOP current <1uA

1 GENERAL DESCRIPTION

The SC92F7323/7322/7321/7320 (hereinafter referred to as the SC92F732X) is a kind of enhanced high-speed 1T 8051-based industrial Flash Microcontroller unit (MCU), in which the instruction system is completely compatible with standard 8051 product series.

The SC92F732X is integrated with 8K bytes Flash ROM, 256 bytes+256 bytes SRAM, 128 bytes EEPROM, up to 26 General-purpose I/Os (GPIO), 14 IO external interrupters, three 16-bit timers, 11-channel 12-bit high-precision ADC, 3-channel independent 8+2-bit PWM and it can switch to 6 output ports, IO ports driven hierarchical control (P0 and P2 ports) with 4-level drive capability, internal $\pm 1\%$ high-precision 24/12/6/2MHz high-frequency oscillator and 4% precision low-frequency 128K oscillator, external crystal oscillator interface, UART communication interface and other resources. To improve the reliability and simplify the circuit design, the SC92F732X is also built in with 4-level optional LVR voltage, 2.4V ADC reference voltage and other high-reliability circuits.

The SC92F732X features excellent anti-interference performance, which make it possible to be widely applied to industrial control system, such as Internet of Things, intelligent home appliances, home automation, wireless communication, gaming peripherals and consumer applications.

2 FEATURES

Operating Voltage: 2.4V ~ 5.5V

Operating Temperature: -40 ~ 85°C

Package:

SC92F7323 (SOP28 / TSSOP28)
SC92F7322 (QFN20 / SOP20 / TSSOP20)
SC92F7321 (SOP16)
SC92F7320 (SOP8)

Core: 1T 8051

Flash ROM: 8K bytes Flash ROM (MOVC) prohibited addressing 0000H ~ 00FFH) can be rewritten for 10,000 times

IAP: Code option into 0K, 0.5K, 1K or 8K

EEPROM: independent 128 bytes EEPROM can be rewritten for 100000 times. The data written-in has more than 10-year preservation life.

SRAM: Internal 256 bytes + external 256 bytes

System Clock (f_{sys}):

- Built-in high-frequency 24MHz oscillator (f_{HRC})
- As the system clock source, f_{sys} can be set to 24MHz(3.7-5.5V), 12/6/2MHz (2.4-5.5V) by programmer selection.
- Frequency Error: Suitable for 4.0V ~ 5.5V and -20 ~ 85°C application environment, no more than $\pm 1\%$ of frequency error

Built-in Low-Frequency Crystal Circuit

- Available to externally connect 32 KHz Oscillator, as the clock source of Base Timer ,it can wake up stop mode

Built-in Low-Frequency 128kHz Oscillator (LRC):

- Clock source of Base Timer (BTM), which can wake up the SC92F732X from stop mode
- Frequency Error: 4.0V ~ 5.5V and -20 ~ 85°C application environment, no more than $\pm 4\%$ of frequency error

Built-in 2KHz Oscillator

- Clock source of Watchdog (WDT)

Low-voltage Reset (LVR):

- 4-level LVR voltage options: 4.3V, 3.7V, 2.9V, 2.3V
- The default is the Code Option value selected by the user

Flash Programming and Emulation:

- 2-wire JTAG programming and emulation interface

Interruption (INT):

- 10 interrupt sources: Timer0, Timer1, Timer2, INT0 ~ 2, ADC, PWM, UART and Base Timer.

- 3 external interrupt vectors shared by 14 interrupt ports, all of which can be defined in rising-edge, falling-edge or dual-edge trigger mode.
- Two-level interrupt priority capability

Digital Peripheral:

- Up to 26 bidirectional independently controllable I/O interfaces, able to configure pull-high resistor independently
- P0/P2 ports with 4-level drive capability
- All I/Os equipped with sink current drive capability (70 mA)
- 11-bit WDT with optional clock division ratio
- 3 standard 80C51 Timer/Counters: Timer0, Timer1 and Timer2
- Timer2 can be configured as a Capture
- Three 8+2-bit PWM output channels with variable period and individual duty cycle, which

can switch to different port outputs (6 outputs in total)

- 5 I/Os as output of the 1/2-bias LCD COM
- 1 independent UART communication interface

Analog Peripheral:

- 11-channel 12-bit ± 2 LSB ADC
 - Built-in 2.4V reference voltage
 - 2 options for ADC reference voltage: V_{DD} and internal 2.4V
 - Internal one-channel ADC, where V_{DD} can be measured directly
 - ADC conversion completion interrupt

Power Saving Mode:

- IDLE Mode: can be woken up by any interrupt.
- STOP Mode: current $< 1\mu A$, can be woken up by INT0 ~ 2 and Base Timer

NAMING RULES FOR 92 SERIES PRODUCTS

Name	SC	92	F	7	3	2	3	X	M	28	U
S/R	①	②	③	④	⑤	⑥	⑦	⑧	⑨	⑩	⑪

S/R	Meaning
①	SinOne Chip abbreviation
②	Name of product series
③	Product Type (F: Flash MCU)
④	Serial Number: 7: GP Series, 8: TK series
⑤	ROM Size: 1 for 2K, 2 for 4K, 3 for 8K, 4 for 16K and 5 for 32K...
⑥	Subseries Number.: 0 ~ 9, A ~ Z
⑦	Number of Pins: 0: 8pin, 1: 16pin, 2: 20pin, 3: 28pin, 5: 32pin, 6: 44pin, 7: 48pin, 8: 64pin, 9: 100pin
⑧	Version Number: (default, B, C, D)
⑨	Package Type: (D: DIP; M: SOP; X: TSSOP; F: QFP; P: LQFP; Q: QFN; K: SKDIP)
⑩	Number of Pins.
⑪	Packaging Mode: (U: Tube; R: Tray; T: Reel)

CONTENTS

1 GENERAL DESCRIPTION	1
2 FEATURES.....	1
NAMING RULES FOR 92 SERIES PRODUCTS.....	3
CONTENTS	4
3 PIN DESCRIPTION	7
3.1 Pin Configuration	7
3.2 Pin Definition	10
4 INNER BLOCK DIAGRAM	12
5 FLASH ROM AND SRAM STRUCTURE	13
5.1 flash rom	13
5.2 CUSTOMER OPTION area (User Programming Setting).....	14
5.2.1 OPTION-RELATED SFR OPERATING INSTRUCTIONS	17
5.3 SRAM.....	18
5.3.1 Internal 256 bytes SRAM.....	18
5.3.2 External 256 bytes SRAM.....	19
6 SPECIAL FUNCTION REGISTER (SFR).....	20
6.1 SFR Mapping	20
6.2 SFR Instructions	21
6.2.1 Introduction to 8051 CPU Core Commonly-used Special function Registers	25
7 POWER, RESET AND CLOCK	27
7.1 Power Circuit	27
7.2 Power-on Reset Process.....	27
7.2.1 Reset Stage	27
7.2.2 Loading Information Stage.....	27
7.2.3 Normal Operating Stage	27
7.3 Reset Mode.....	27
7.3.1 External RST RESET	27
7.3.2 Low-voltage Reset LVR	27
7.3.3 Power-on Reset (POR).....	29
7.3.4 Watchdog Reset (WDT).....	29
7.3.5 reset initial state	30
7.4 High-speed RC Oscillator Circuit	32

7.5 Low-speed RC Oscillator and Low-speed Clock Timer	35
7.6 STOP Mode and IDLE Mode.....	37
8 CPU AND FUNCTION SYSTEM	39
8.1 CPU.....	39
8.2 Addressing Mode.....	39
8.2.1 Immediate Addressing	39
8.2.2 Direct Addressing	39
8.2.3 Indirect Addressing	39
8.2.4 Register Addressing	39
8.2.5 Relative Addressing.....	39
8.2.6 Indexed Addressing	40
8.2.7 Bits Addressing.....	40
9 INTERRUPT	40
9.1 Interrupt Source and Vector	40
9.2 Interrupt Structure Diagram.....	42
9.3 Interrupt Priority.....	43
9.4 Interrupt Processing Flow.....	43
9.5 Interrupt-related SFR Registers	43
10 TIMER / EVENT COUNTER TIMER0 AND TIMER1	51
10.1 T0 and T1-related Special function Registers.....	51
10.2 T0 Operating Mode	56
10.3 T1 Operating Mode	58
11 TIMER / EVENT COUNTER TIMER2	60
11.1 T2-related SFR.....	60
11.2 T2 Operating Mode	64
12 PWM	69
12.1 PWM block Diagram	69
12.2 PWM-related SFR Registers.....	70
12.3 PWM Waveform and Directions.....	77
13 GP I/O	80
13.1 GPIO Structure Diagram.....	80
13.2 I/O Port-related Registers.....	81

14 SOFTWARE LCD DRIVER.....	86
14.1 Software LCD Drives Relevant Registers.....	86
15 UART	87
15.1 UART Related Register (Read/Write)	87
15.2 Baud Rate of Serial Communication.....	89
16 ANALOG-TO-DIGITAL CONVERTER (ADC)	90
16.1 ADC-related Registers.....	90
16.2 ADC Conversion Steps.....	95
17 EEPROM AND IAP OPERATIONS	96
17.1 EEPROM / IAP Operating-related Registers.....	96
17.2 EEPROM / IAP Operating Procedures:	100
17.2.1 128 bytes Independent EEPROM Operating Demo programme	101
17.2.2 Code memory IAP Operating Demo programme	102
18 ELECTRICAL CHARACTERISTICS	104
18.1 absolute maximum ratings	104
18.2 Recommended Operating Conditions	104
18.3 D.C. Characteristics	104
18.4 AC Electrical features.....	108
18.5 ADC Electrical Features	108
19 ORDERING INFORMATION	110
20 PACKAGEING INFORMATION	111
21 REVISION HISTORY	125

3 PIN DESCRIPTION

3.1 Pin Configuration

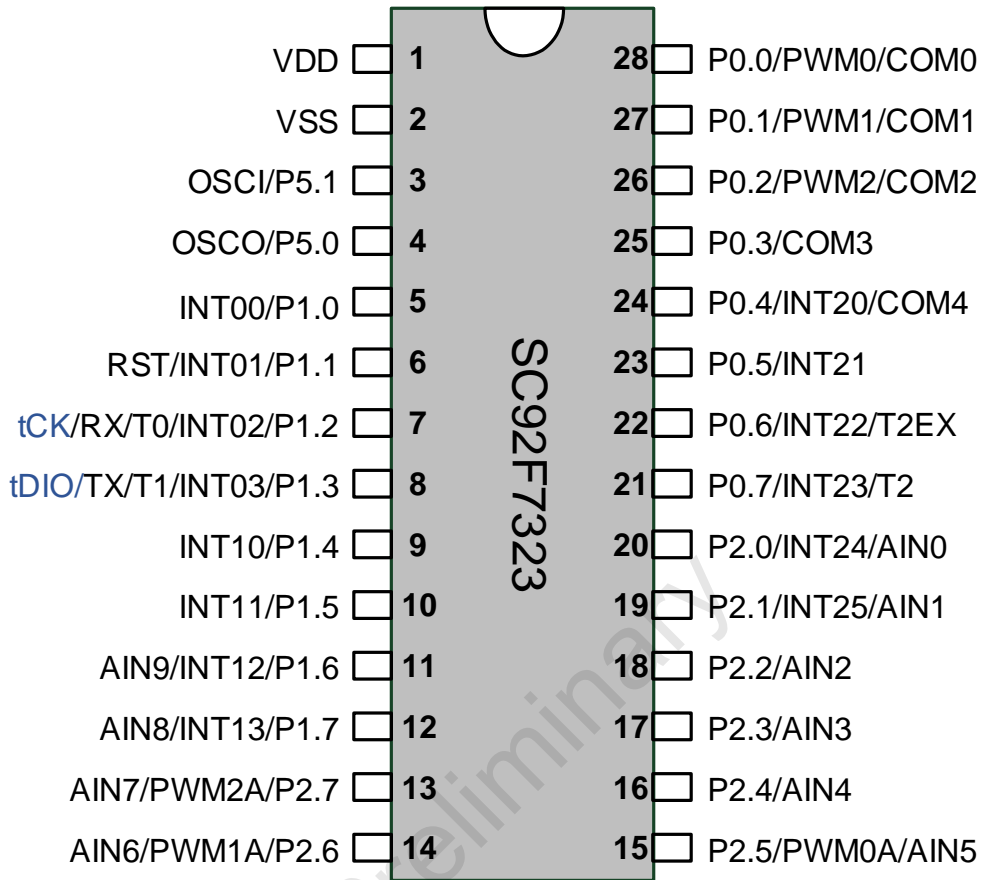

The SC92F7323 Pin Diagram

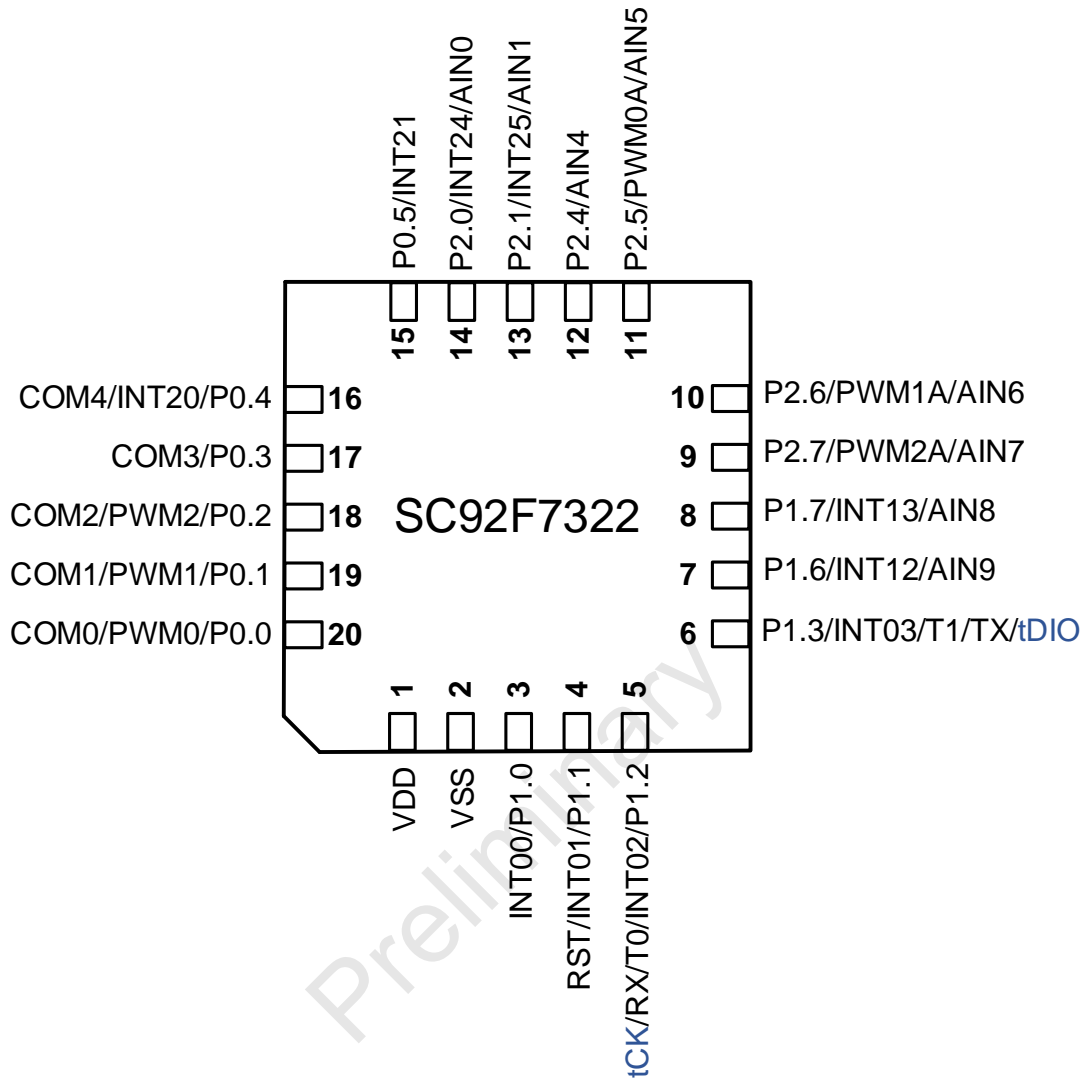

The SC92F7322 Pin Diagram (QFN20)

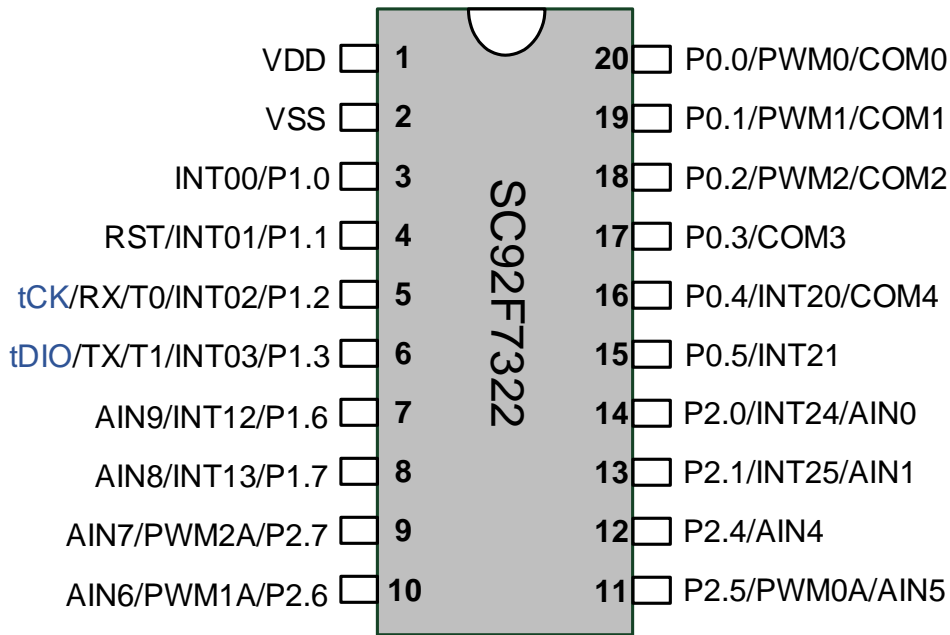

The SC92F7322 Pin Diagram (SOP20/TSSOP20)

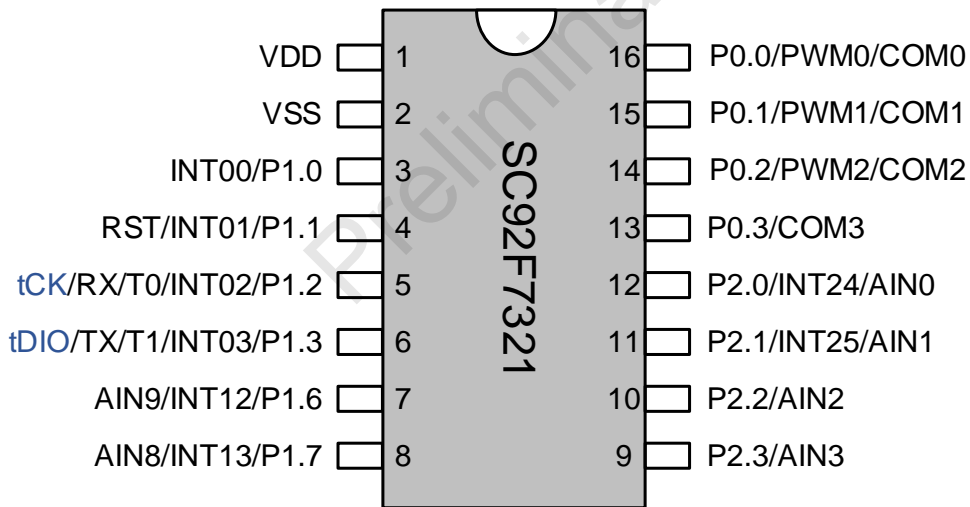

The SC92F7321 Pin Diagram

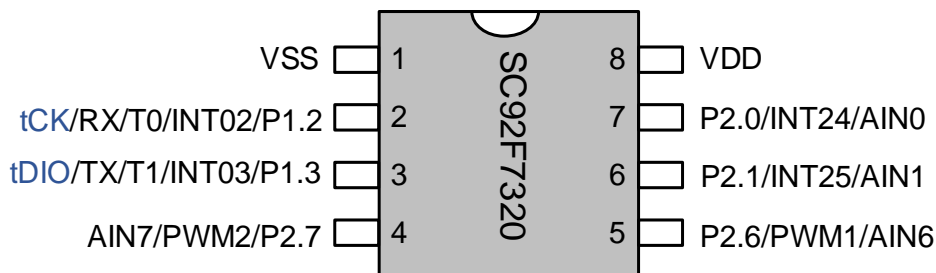

The SC92F7320 Pin Diagram

3.2 Pin Definition

Pin #				Pin Name	Type	Description
28PIN	20PIN	16PIN	8PIN			
1	1	1	8	VDD	Power	Power
2	2	2	1	VSS	Power	Ground
3	-	-	-	P5.1/OSCI	I/O	P5.1: GPIO P5.1 OSCI: External 32KHz crystal oscillator input
4	-	-	-	P5.0/OSCO	I/O	P5.0: GPIO P5.0 OSCO: External 32KHz crystal oscillator output
5	3	3	-	P1.0/INT00	I/O	P1.0: GPIO P1.0 INT00: Input 0 of external interrupt 0
6	4	4	-	P1.1/INT01/RST	I/O	P1.1: GPIO P1.1 INT01: Input 1 of external interrupt 0 RST: Reset Pin
7	5	5	2	P1.2/INT02/T0/RX/tCK	I/O	P1.2: GPIO P1.2 INT02: Input 2 of external interrupt 0 T0: Timer/Counter 0 External Input RX: UART Receiver tCK: Programming and Emulation Clock Pin
8	6	6	3	P1.3/INT03/T1/TX/tDIO	I/O	P1.3: GPIO P1.3 INT03: Input 3 of external interrupt 0 T1: Timer/Counter 1 External Input TX: UART Transmitter tDIO: Programming and Emulation Data Pin
9	-	-	-	P1.4/INT10	I/O	P1.4: GPIO P1.4 INT10: Input 0 of external interrupt 1
10	-	-	-	P1.5/INT11	I/O	P1.5: GPIO P1.5 INT11: Input 1 of external interrupt 1
11	7	7	-	P1.6/INT12/AIN9	I/O	P1.6: GPIO P1.6 INT12: Input 2 of external interrupt 1 AIN9: ADC Input Channel 9
12	8	8	-	P1.7/INT13/AIN8	I/O	P1.7: GPIO P1.7 INT13: Input 3 of external interrupt 1 AIN8: ADC Input Channel 8
13	9	-	4	P2.7/PWM2A/AIN7	I/O	P2.7: GPIO P2.7 PWM2A: one of PWM2 Output AIN7: ADC Input Channel 7
14	10	-	5	P2.6/PWM1A/AIN6	I/O	P2.6: GPIO P2.6 PWM1A: one of PWM1 Output AIN6: ADC Input Channel 6
15	11	-	-	P2.5/PWM0A/AIN5	I/O	P2.5: GPIO P2.5 PWM0A: one of PWM0 Output AIN5: ADC Input Channel 5
16	12	-	-	P2.4/AIN4	I/O	P2.4: GPIO P2.4 AIN4: ADC Input Channel 4
17	-	9	-	P2.3/AIN3	I/O	P2.3: GPIO P2.3

						AIN3: ADC Input Channel 3
18	-	10	-	P2.2/AIN2	I/O	P2.2: GPIO P2.2 AIN2: ADC Input Channel 2
19	13	11	6	P2.1/INT25/AIN1	I/O	P2.1: GPIO P2.1 INT25: Input 5 of external interrupt 2 AIN1: ADC Input Channel 1
20	14	12	7	P2.0/INT24/AIN0	I/O	P2.0: GPIO P2.0 INT24: Input 4 of external interrupt 2 AIN0: ADC Input Channel 0
21	-	-	-	P0.7/INT23/T2	I/O	P0.7: GPIO P0.7 INT23: Input 3 of external interrupt 2 T2: Timer/Counter 2 External input
22	-	-	-	P0.6/INT22/T2EX	I/O	P0.6: GPIO P0.6 INT22: Input 2 of external interrupt 2 T2EX: External Signal Input Capture for Timer2
23	15	-	-	P0.5/INT21	I/O	P0.5: GPIO P0.5 INT21: Input 1 of external interrupt 2
24	16	-	-	P0.4/INT20/COM4	I/O	P0.4: GPIO P0.4 INT20: Input 0 of external interrupt 2 COM4: LCD common drive output 4
25	17	13	-	P0.3/COM3	I/O	P0.3: GPIO P0.3 COM3: LCD common drive output 3
26	18	14	-	P0.2/PWM2/COM2	I/O	P0.2: GPIO P0.4 PWM2: one of PWM2 Output COM2: LCD common drive output 2
27	19	15	-	P0.1/PWM1/COM1	I/O	P0.1: GPIO P0.1 PWM1: one of PWM1 Output COM1: LCD common drive output 1
28	20	16	-	P0.0/PWM0/COM0	I/O	P0.0: GPIO P0.0 PWM0: one of PWM0 Output COM0: LCD common drive output 0

4 INNER BLOCK DIAGRAM

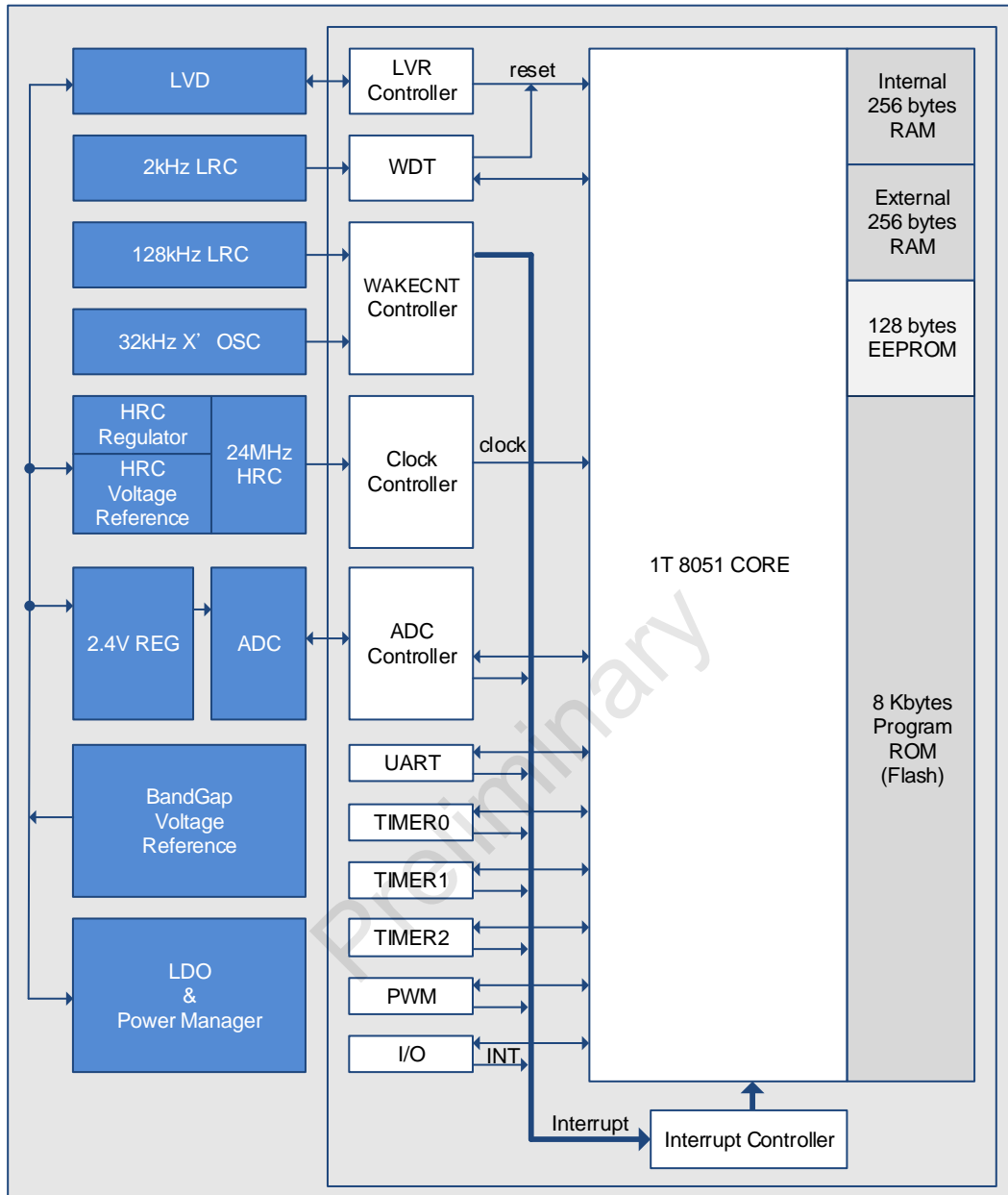

The SC92F732X BLOCK DIAGRAM

5 FLASH ROM AND SRAM STRUCTURE

The structures of the SC92F732X's Flash ROM and SRAM are shown as follows:

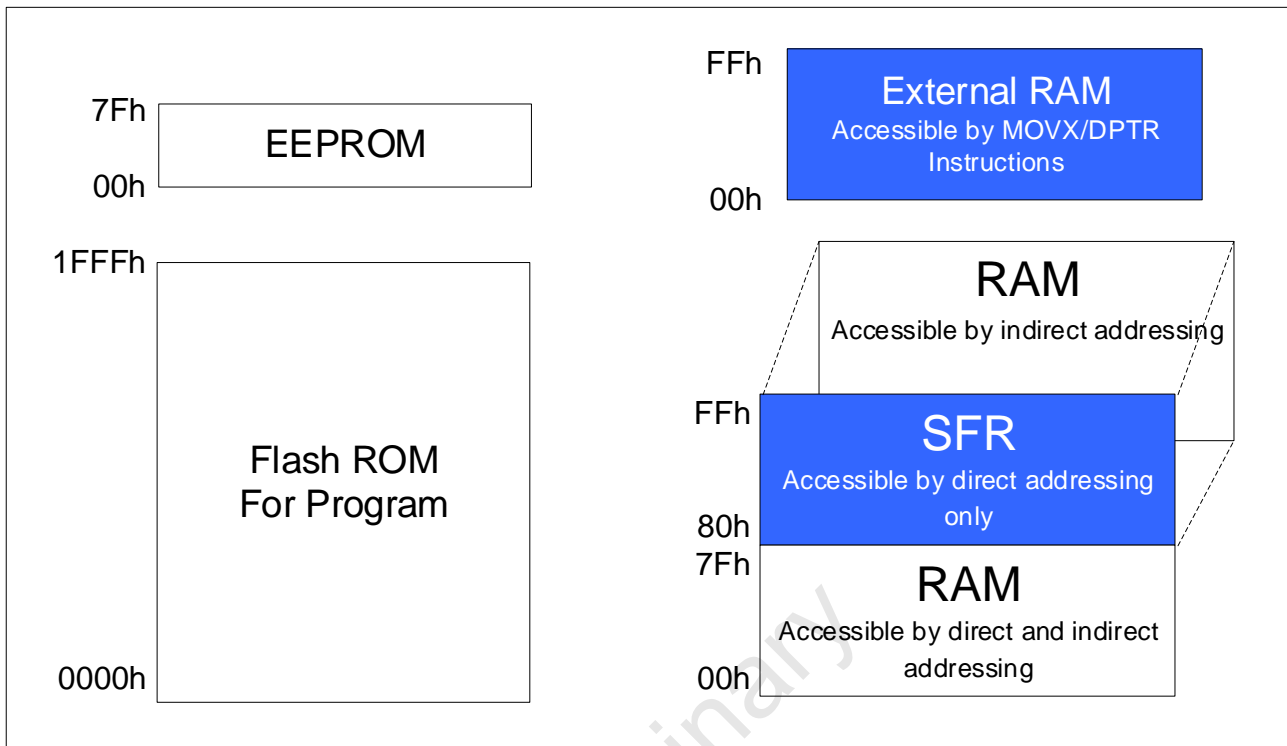

Flash ROM and SRAM Structure Diagram

5.1 flash rom

The SC92F732X provides 8 Kbytes of Flash ROM with the ROM address of 0000H ~ 1FFFH. These 8 Kbytes of Flash ROM can be rewritten 10,000 times, which is able to programming and erasing by specialized ICP programming device (SOC PRO52/DPT52/SC LINK) provided by SinOne. MOVC instruction is non-addressable within 256 bytes (address of 0000H ~ 00FFH).

EEPROM is an area separated from 8K bytes ROM with the address of 00H ~ 7FH, which can be accessed by single-byte reading and writing operations in the programme; for more details, refer to [17 EEPROM and IAP Operations](#).

The SC92F732X Flash ROM can be programmed by tDIO, tCK, VDD and VSS, with its specific connection shown as follows:

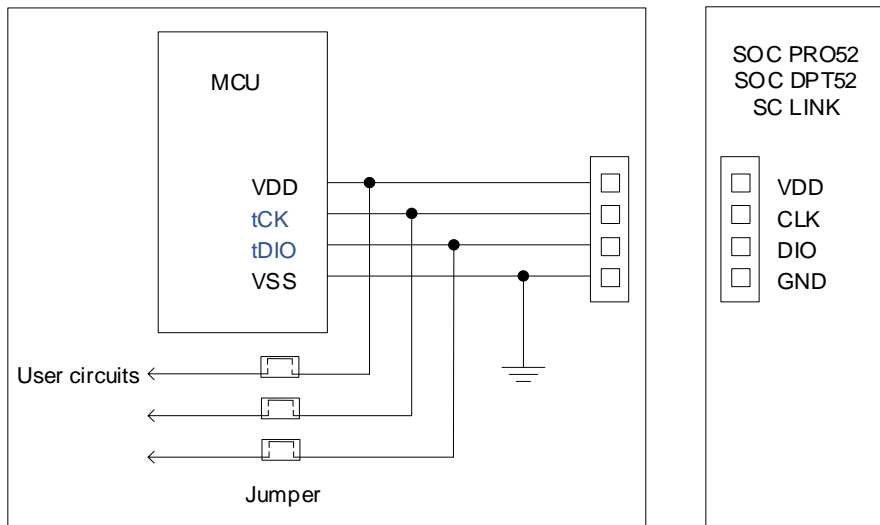

ICP Mode Flash Writer Programming Connection Diagram

5.2 CUSTOMER OPTION area (User Programming Setting)

A separate Flash area is embedded inside the SC92F732X, called Customer Option area, to save the user's presets. These presets will be written into IC when programming and loaded into SFR as default values during reset.

Option-related SFR Operating Instructions:

Reading and writing operations to option-related SFR are controlled by both register OPINX and register OPREG, with its respective address of Option SFR depending on register OPINX, as shown below:

Symbol	Address	Description	7	6	5	4	3	2	1	0
OP_HRCR	83H@FFH	High-frequency RC oscillation frequency regulation	OP_HRCR[7: 0]							
OP_CTM0	C1H@FFH	Customer Option Register 0	ENWD T	ENXTL	SCLKS[1: 0]		DISRS T	DISLV R	LVRS[1: 0]	
OP_CTM1	C2H@FFH	Customer Option Register 1	VREFS	-	-	-	IAPS[1: 0]		-	-

OP_HRCR (83H@FFH) System Clock Change Register (Read/Write)

Bit Number	7	6	5	4	3	2	1	0
Bit Symbol	OP_HRCR[7: 0]							
R/W	R/W							

POR	n	n	n	n	n	n	n	n
-----	---	---	---	---	---	---	---	---

Bit Number	Bit Symbol	Description
7 ~ 0	OP_HRCR[7: 0]	Internal high-frequency RC frequency adjustment Central value 10000000b corresponds to HRC central frequency, the larger the value is, the faster the frequency will be, vice versa.

OP_CTM0 (C1H@FFH) Customer Option Register0 (Read/Write)

Bit Number	7	6	5	4	3	2	1	0
Bit Symbol	ENWDT	ENXTL	SCLKS[1: 0]		DISRST	DISLVR	LVRS[1: 0]	
R/W	R/W	R/W	R/W		R/W	R/W	R/W	
POR	n	n	n		n	n	n	

Bit Number	Bit Symbol	Description
7	ENWDT	Watchdog (WDT) control bit (This bit is transferred by the system to the value set by the user Code Option) 0: WDT invalid 1: WDT valid (WDT stops counting during IAP execution)
6	ENXTL	External High-Frequency crystal oscillator selection bit 0: External High-Frequency crystal Interface disable, P5.0 and P5.1 valid 1: External High-Frequency crystal Interface enable, P5.0 and P5.1 invalid
5 ~ 4	SCLKS[1: 0]	System clock frequency selection bits 00: Reserved; 01: System clock frequency is HRC frequency divided by 2;

		10: System clock frequency is HRC frequency divided by 4; 11: System clock frequency is HRC frequency divided by 12;
3	DISRST	IO/RST selection bit 0: configure P1.1 as External Reset input pin 1: configure P1.1 as GPIO
2	DISLVR	LVR control bit 0: LVR valid 1: LVR invalid
1 ~ 0	LVRS [1: 0]	LVR voltage selection bits 11: 4.3V reset 10: 3.7 V reset 01: 2.9V reset 00: 2.3 V reset

OP_CTM1 (C2H@FFH) Customer Option Register1 (Read/Write)

Bit Number	7	6	5	4	3	2	1	0
Bit Symbol	VREFS	-	-	-	IAPS[1: 0]		-	-
R/W	R/W	-	-	-	R/W	R/W	-	-
POR	n	x	x	x	n	n	x	x

Bit Number	Bit Mnemonic	Description
7	VREFS	Reference voltage selection bit (Initial values are configured by the user and loaded from Code Options) 0: Configure ADC VREF as V _{DD} 1: Configure ADC VREF as internally correct 2.4V

3 ~ 2	IAPS[1: 0]	EEPROM and IAP Area Selection Bits 00: Code memory prohibits IAP operations, only EEPROM data memory is used for data storage 01: last 0.5k code memory allows IAP operation (1E00H ~ 1FFFH) 10: Last 1k code memory allows IAP operation (1C00H ~ 1FFFH) 11: All code memory allows IAP operation (0000H ~ 1FFFH)
6 ~ 4, 1 ~ 0	-	Reserved

5.2.1 OPTION-RELATED SFR OPERATING INSTRUCTIONS

Option-related SFR reading and writing operations are controlled by both OPINX and OPREG registers, with its respective position of Option SFR depending on OPINX and its value written to option-related SFR depending on register OPREG:

Symbol	Address	Description		POR
OPINX	FEH	Option Pointer	OPINX[7: 0]	00000000b
OPREG	FFH	Option Register	OPREG[7: 0]	nnnnnnnnb

When operating Option-related SFR, register OPINX stores the address of option-related registers and register OPREG stores corresponding value.

For example: To configure OP_HRCR as 0x01, specific operation method is shown below:

C program example:

```
OPINX = 0x83;           //Write OP_HRCR address into OPINX register
OPREG = 0x01;          //Write 0x01 into OPREG register (the value to be written into OP_HRCR register)
```

Assembler program example:

```
MOV OPINX, #83H        ;Write OP_HRCR address into OPINX register
MOV OPREG, #01H        ;Write 0x01 into OPREG register (the value to be written into OP_HRCR register)
```

Note: It is forbidden to write any value beyond SFR address of Customer Option region into OPINX register! Or else, it may cause abnormal system operation

5.3 SRAM

The SRAM of the SC92F732X Microcontroller Unit is divided into internal 256 bytes RAM and external 256 bytes RAM. The address of Internal RAM range from 00H to FFH, including high 128 bytes (address of from 80H to FFH) only addressed indirectly and low 128 bytes (address of from 00H to 7FH) addressed both directly and indirectly).

The address of special function register SFR is also from 80H to FFH. But the difference between SFR and internal high 128 bytes SRAM is that the former is addressed directly but the latter addressed indirectly only.

The address of External RAM from 0000H to 02FFH, which is addressed by MOVX instruction.

5.3.1 INTERNAL 256 BYTES SRAM

Internal low 128 bytes SRAM area is divided into three parts: ① Register bank 0 ~ 3, address from 00H to 1FH. The active bank is selected by bits RS1 and RS0 of PSW register. Using Register bank 0 ~ 3 can accelerate arithmetic speed; ② Bit addressing area , 20H ~2FH; user can use it as normal RAM or bitwise addressing RAM; for the latter, the bit address is from 00H to 7FH (bitwise addressing is different from normal SRAM byte-oriented addressing), which can be distinguished by instructions in programme; ③ User RAM and stack area, the 8-bit stack pointer will point to stack area after the SC92F732X reset; in general, users can set initial value in initializer, which is recommended to configure in the unit interval from E0H to FFH.

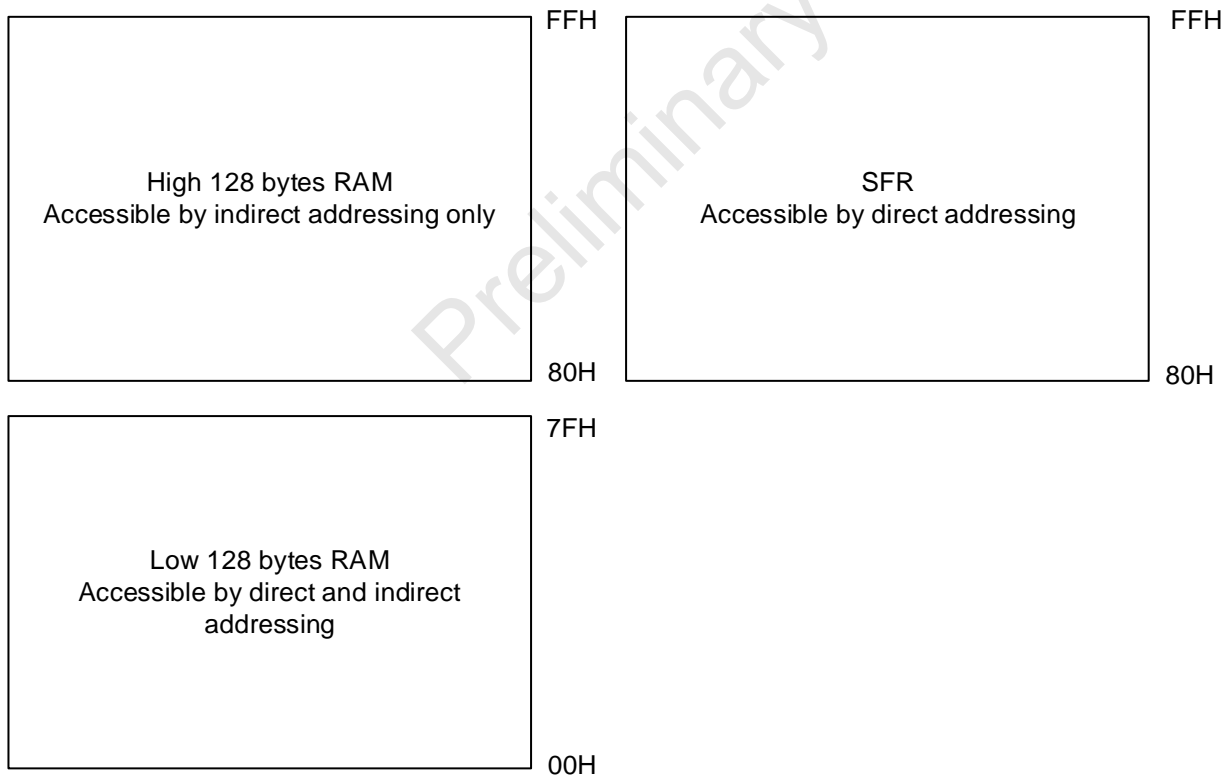

Internal 256 bytes RAM Structure Diagram

Internal low 128 bytes RAM structure is shown below:

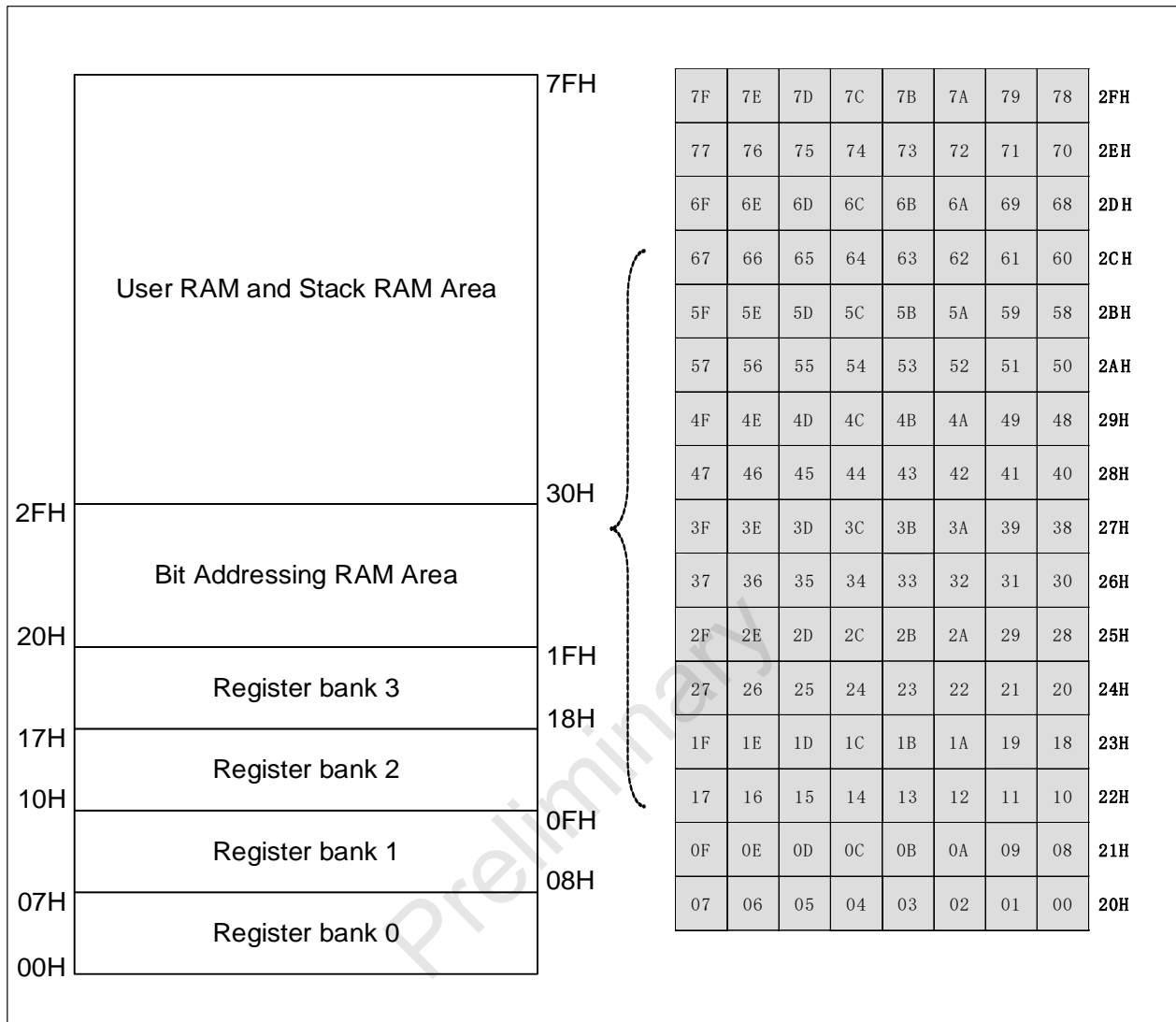

SRAM Structure Diagram

5.3.2 EXTERNAL 256 BYTES SRAM

The external 256 bytes RAM (SRAM) can be accessed by instruction “MOVX A ,@Ri” or “MOVX @Ri, A” or instruction “MOVX A, @DPTR” or “MOVX @DPTR, A”.

6 SPECIAL FUNCTION REGISTER (SFR)

6.1 SFR Mapping

The SC92F732X provides some registers equipped with special functions, called SFR. The address of such SFRs is from 80H to FFH, some are bit-addressable, and others are not. It is very convenient for these bit addressable registers to change the value of single bit, of which the address is end up with figure "0" or "8". All SFR shall use direct addressing for addressing.

The name and address of the SC92F732X special function registers are shown in the table below:

	0/8	1/9	2/A	3/B	4/C	5/D	6/E	7/F
F8h	-	-	-	-	-	-	OPINX	OPREG
F0h	B	IAPKEY	IAPADL	IAPADH	IAPADE	IAPDAT	IAPCTL	-
E8h	-	-	-	-	-	-	-	-
E0h	ACC	-	-	-	-	-	-	-
D8h	P5	P5CON	P5PH	-	-	-	-	-
D0h	PSW	PWMCFG	PWMCON	PWMPRD	PWMDTYA	PWMDTY0	PWMDTY1	PWMDTY2
C8h	T2CON	T2MOD	RCAP2L	RCAP2H	TL2	TH2	BTMCON	WDTCON
C0h	-	-	-	-	-	-	INT2F	INT2R
B8h	IP	IP1	INT0F	INT0R	INT1F	INT1R	-	-
B0h	-	-	-	-	-	-	-	-
A8h	IE	IE1	-	ADCCFG0	ADCCFG1	ADCCON	ADCVL	ADCVH
A0h	P2	P2CON	P2PH	-	-	-	-	-
98h	SCON	SBUF	P0CON	P0PH	P0VO	-	-	-
90h	P1	P1CON	P1PH	-	-	-	-	IOHCON
88h	TCON	TMOD	TL0	TL1	TH0	TH1	TMCON	OTCON

80h	P0	SP	DPL	DPH	-	-	-	PCON
	Bit Addressable	Not Bit Addressable						

Notes:

1. Hollow space of SFR refers to the fact that there is no such register RAM, it is not recommended for user to use.

6.2 SFR Instructions

For a description of each SFR, see the following table:

Register Name	Address	Description	7	6	5	4	3	2	1	0	Initial value	
P0	80H	P0 Data Register	P07	P06	P05	P04	P03	P02	P01	P00	00000000b	
SP	81H	Stack Pointer	SP[7: 0]									00000111b
DPL	82H	Data Pointer Low byte	DPL[7: 0]									00000000b
DPH	83H	Data Pointer High byte	DPH[7: 0]									00000000b
PCON	87H	Power Management Control Register	SMOD	-	-	-	-	-	STOP	IDL	0xxxxx00b	
TCON	88H	Timer Control Register	TF1	TR1	TF0	TR0	-	-	-	-	00000x0xb	
TMOD	89H	Timer Operating Mode Register	-	C/T1	M11	M01	-	C/T0	M10	M00	x000x000b	
TL0	8AH	Timer0 Low 8 bits	TL0[7: 0]									00000000b
TL1	8BH	Timer1 Low 8 bits	TL1[7: 0]									00000000b
TH0	8CH	Timer0 High 8 bits	TH0[15: 8]									00000000b
TH1	8DH	Timer1 High 8 bits	TH1[15: 8]									00000000b
TMCON	8EH	Timer Frequency Control Register	-	-	-	-	-	T2FD	T1FD	T0FD	xxxxx000b	

OTCON	8FH	Output Control Register	-	-	-	VOIRS[1: 0]				-	-	xxxx00xxb
P1	90H	P1 Data Register	P17	P16	P15	P14	P13	P12	P11	P10	00000000b	
P1CON	91H	P1 Input / Output Control Register	P1C7	P1C6	P1C5	P1C4	P1C3	P1C2	P1C1	P1C0	00000000b	
P1PH	92H	P1 Pull-up Resistor Control Register	P1H7	P1H6	P1H5	P1H4	P1H3	P1H2	P1H1	P1H0	00000000b	
IOHCON	97H	IOH Setup Register	P2H[1: 0]		P2L[1: 0]		P0H[1: 0]		P0L[1: 0]		00000000b	
SCON	98H	Serial Port Control Register	SM0	SM1	SM2	REN	TB8	RB8	TI	RI	00000000b	
SBUF	99H	Serial Port Data Cache Register	SBUF[7: 0]								00000000b	
P0CON	9AH	P0 Input / Output Control Register	P0C7	P0C6	P0C5	P0C4	P0C3	P0C2	P0C1	P0C0	00000000b	
P0PH	9BH	P0 Pull-up Resistor Control Register	P0H7	P0H6	P0H5	P0H4	P0H3	P0H2	P0H1	P0H0	00000000b	
P0VO	9CH	P0 Port LCD Voltage Output Register	-	-	-	P04VO	P03VO	P02VO	P01VO	P00VO	xxx00000b	
P2	A0H	P2 Data Register	P27	P26	P25	P24	P23	P22	P21	P20	00000000b	
P2CON	A1H	P2 Input / Output Control Register	P2C7	P2C6	P2C5	P2C4	P2C3	P2C2	P2C1	P2C0	00000000b	
P2PH	A2H	P2 Pull-up Resistor Control Register	P2H7	P2H6	P2H5	P2H4	P2H3	P2H2	P2H1	P2H0	00000000b	
IE	A8H	Interrupt Enable Register	EA	EADC	ET2	EUART	ET1	EINT1	ET0	EINT0	00000000b	
IE1	A9H	Interrupt Enable Register 1	-	-	-	-	EINT2	EBTM	EPWM	-	xxx00000b	
ADCCFG0	ABH	ADC Configuration Register 0	EAIN7	EAIN6	EAIN5	EAIN4	EAIN3	EAIN2	EAIN1	EAIN0	00000000b	
ADCCFG1	ACH	ADC Configuration Register 1	-	-	-	-	-	-	EAIN9	EAIN8	xxxxxx00b	
ADCCON	ADH	ADC Control Register	ADCEN	ADCS	EOC/ ADCIF	ADCIS[4: 0]				00000000b		

ADCVL	AEH	ADC Result Register	ADC[3: 0]				-	-	-	-	0000xxxxb
ADCVH	AFH	ADC Result Register	ADC[11: 4]								00000000b
IP	B8H	Interrupt Priority Control Register	-	IPADC	IPT2	IPUART	IPT1	IPINT1	IPT0	IPINT0	x0000000b
IP1	B9H	Interrupt Priority Control Register 1	-	-	-	-	IPINT2	IPBTM	IPPWM	-	xxx00000b
INT0F	BAH	INT0 Falling Edge Interrupt Control Register	-	-	-	-	INT0F3	INT0F2	INT0F1	INT0F0	xxxx000xb
INT0R	BBH	INT0 Rising Edge Interrupt Control Register	-	-	-	-	INT0R3	INT0R2	INT0R1	INT0R0	xxxx000xb
INT1F	BCH	INT1 Falling Edge Interrupt Control Register	-	-	-	-	INT1F3	INT1F2	INT1F1	INT1F0	xxxx0000b
INT1R	BDH	INT1 Rising Edge Interrupt Control Register	-	-	-	-	INT1R3	INT1R2	INT1R1	INT1R0	xxxx0000b
INT2F	C6H	INT2 Falling Edge Interrupt Control Register	-	-	INT2F5	INT2F4	INT2F3	INT2F2	INT2F1	INT2F0	xx000000b
INT2R	C7H	INT2 Rising Edge Interrupt Control Register	-	-	INT2R5	INT2R4	INT2R3	INT2R2	INT2R1	INT2R0	xx000000b
T2CON	C8H	Timer2 Control Register	TF2	EXF2	RCLK	TCLK	EXEN2	TR2	C/T2	CP/RL2	00000000b
T2MOD	C9H	Timer2 Operating Mode Register	-	-	-	-	-	-	T2OE	DCEN	xxxxxx00b
RCAP2L	CAH	Timer2 Reload Low 8 bits	RCAP2L[7: 0]								00000000b
RCAP2H	CBH	Timer2 Reload High 8 bits	RCAP2H[7: 0]								00000000b
TL2	CCH	Timer2 Low 8 bits	TL2[7: 0]								00000000b
TH2	CDH	Timer2 High 8 bits	TH2[7: 0]								00000000b
BTMCON	CEH	Low-Frequency Timer Control Register	ENBTM	BTMIF	-	-	-	BTMFS[2: 0]			00xxx000b
WDTCON	CFH	WDT Control Register	-	-	-	CLRWDT	-	WDTCKS[2: 0]			xxx0x000b
PSW	D0H	Program Status Word Register	CY	AC	F0	RS1	RS0	OV	F1	P	00000000b

PWMCFG	D1H	PWM Setup Register	-		INV2	INV1	INV0	PWMOS2	PWMOS1	IPWMOS0	0000000b
PWMCON	D2H	PWM Control Register	ENPWM	PWMIF	ENPWM2	ENPWM1	ENPWM0	PWMCKS 2	PWMCKS 1	PWMCKS0	0000000b
PWMPRD	D3H	PWM Period Setting Register	PWMPRD[7: 0]								0000000b
PWMDTYA	D4H	PWM0 duty cycle setting register A	-		PDTA2[1: 0]		PDTA1[1: 0]		PDTA0[1: 0]		xx00000b
PWMDTY0	D5H	PWM0 duty cycle setting register	PDT0[7: 0]								0000000b
PWMDTY1	D6H	PWM1 duty cycle setting register	PDT1[7: 0]								0000000b
PWMDTY2	D7H	PWM2 duty cycle setting register	PDT2[7: 0]								0000000b
P5	D8H	P5 Data Register	-	-	-	-	-	-	P51	P50	xxxxx00b
P5CON	D9H	P5 Input / Output Control Register	-	-	-	-	-	-	P5C1	P5C0	xxxxx00b
P5PH	DAH	P5 Pull-up Resistor Control Register	-	-	-	-	-	-	P5H1	P5H0	xxxxx00b
ACC	E0H	Accumulator	ACC[7: 0]								0000000b
B	F0H	B Register	B[7: 0]								0000000b
IAPKEY	F1H	IAP Protection Register	IAPKEY[7: 0]								0000000b
IAPADL	F2H	IAP Address Low byte Register	IAPADR[7: 0]								0000000b
IAPADH	F3H	IAP Address High byte Register	-	-	-	IAPADR[12: 8]				xxx0000b	
IAPADE	F4H	IAP Extended Address Register	IAPADER[7: 0]								0000000b
IAPDAT	F5H	IAP Data Register	IAPDAT[7: 0]								0000000b
IAPCTL	F6H	IAP Control Register	-	-	-	-	PAYTIMES[1: 0]		CMD[1: 0]		xxxx000b
OPINX	FEH	Option Pointer	OPINX[7: 0]								0000000b

OPREG	FFH	Option Register	OPREG[7: 0]	nnnnnnnb
-------	-----	-----------------	-------------	----------

6.2.1 INTRODUCTION TO 8051 CPU CORE COMMONLY-USED SPECIAL FUNCTION REGISTERS

Program Counter (PC)

PC does not belong to SFR. 16-bit PC is the register used to control instruction execution sequence. After power-on or reset of microcontroller unit, PC value is 0000H, that is to say, the microcontroller unit is to execute program from 0000H.

Accumulator ACC (E0H)

Accumulator ACC is one of the commonly-used registers in 8051-based microcontroller unit, using A as mnemonic symbol in the instruction system. It is usually used to store operand and results for calculation or logical operations.

B Register (F0H)

B Register shall be used together with Accumulator A in multiplication and division operations. For example, instruction "MUL A, B" is used to multiply 8-bit unsigned numbers of Accumulator A and Register B. As for the acquired 16-bit product, low byte is placed in A and High byte in B. As for "DIV A, B" is used to divide A by B, place integer quotient in A and remainder in B. Register B can also be used as common temporary register.

Stack Pointer SP (81H)

Stack pointer is an 8-bit specialized register, it indicates the address of top stack in common RAM. After resetting of microcontroller unit, the initial value of SP is 07H, and the stack will increase from 08H. 08H ~ 1FH is address of register banks 1 ~ 3.

PSW (D0H) Program Status Word Register (Read/Write)

Bit Number	7	6	5	4	3	2	1	0
Bit Symbol	CY	AC	F0	RS1	RS0	OV	F1	P
R/W	R/W	R/W	R/W	R/W	R/W	R/W	R/W	R/W
POR	0	0	0	0	0	0	0	0

Bit Number	Bit Symbol	Description
7	CY	Carry Flag bit 1: The top digit of add operation has carry bit or the top digit of subtraction operation has the borrow digit 0: The top digit of add operation has no carry bit or the top digit of subtraction operation has no borrow digit

6	AC	<p>Carry-bit auxiliary flag bit (adjustable upon BCD code add and subtraction operations)</p> <p>1: There is carry bit in bit 3 upon add operation and borrow bit in bit 3 upon subtraction operation</p> <p>0: No borrow bit and carry bit</p>															
5	F0	User flag bit															
4 ~ 3	RS1,RS0	<p>Register banks selection bits</p> <table border="1" data-bbox="619 672 1348 1153"> <thead> <tr> <th>RS1</th> <th>RS0</th> <th>Current Selected Register banks 0 ~ 3</th> </tr> </thead> <tbody> <tr> <td>0</td> <td>0</td> <td>Group 0 (00H ~ 07H)</td> </tr> <tr> <td>0</td> <td>1</td> <td>Group 1 (08H ~ 0FH)</td> </tr> <tr> <td>1</td> <td>0</td> <td>Group 2 (10H ~ 17H)</td> </tr> <tr> <td>1</td> <td>1</td> <td>Group 3 (18H ~ 1FH)</td> </tr> </tbody> </table>	RS1	RS0	Current Selected Register banks 0 ~ 3	0	0	Group 0 (00H ~ 07H)	0	1	Group 1 (08H ~ 0FH)	1	0	Group 2 (10H ~ 17H)	1	1	Group 3 (18H ~ 1FH)
RS1	RS0	Current Selected Register banks 0 ~ 3															
0	0	Group 0 (00H ~ 07H)															
0	1	Group 1 (08H ~ 0FH)															
1	0	Group 2 (10H ~ 17H)															
1	1	Group 3 (18H ~ 1FH)															
2	OV	Overflow flag bit															
1	F1	<p>F1 flag bit</p> <p>User customized flag</p>															
0	P	<p>Parity flag bit. This flag bit is the parity value of the number of 1 in accumulator ACC.</p> <p>1: Odd number of number of 1 in ACC</p> <p>0: Even number of number of 1 in ACC (including 0)</p>															

Data Pointer DPTR (82H, 83H)

The Data pointer DPTR is a 16-bit dedicated register, which is composed of Low byte DPL (82H) and High byte DPH (83H). DPTR is the only register in the traditional 8051-based MCU that can directly conduct 16-bit operation, which can also conduct operations on DPL and DPH by byte.

7 POWER, RESET AND CLOCK

7.1 Power Circuit

The SC92F732X Power includes circuits such as BG, LDO, POR and LVR, which are able to reliably work within the scope of 2.4V ~ 5.5V. Besides, a calibrated 2.4V voltage is built in the IC, which is used as ADC internal reference voltage. The user can search for specific configuration contents in [16 Analog-to-digital converter \(ADC\)](#).

7.2 Power-on Reset Process

After the SC92F732X power-on, the processes carried out before execution of client software are as follows:

- Reset stage
- Loading information stage
- Normal operation stage

7.2.1 RESET STAGE

The SC92F732X will always be in reset mode. There will not be a valid clock until the voltage supplied to the SC92F732X is higher than certain voltage. The duration of reset stage is related to rising speed of external power. Once the external supply voltage is up to built-in POR voltage, the reset stage would be completed.

7.2.2 LOADING INFORMATION STAGE

There is a preheating counter inside the SC92F732X. During the reset stage, this preheating counter is always reset as zero. After the voltage is higher than POR voltage, internal RC oscillator starts to oscillate and this preheating counter starts to count. When internal preheating counter counts up to certain number, one byte data will be read from IFB of Flash ROM (including Code Option) for every certain number of HRC clock, which is saved to internal system registers. After the preheating is completed, such reset signal will end.

7.2.3 NORMAL OPERATING STAGE

After the loading information stage has been completed, the SC92F732X starts to read instruction code from Flash and enters normal operating stage. At this time, LVR voltage is the set value of Code Option written by user.

7.3 Reset Mode

The SC92F732X has 4 kinds of reset modes: ① External RST reset ② Low-voltage reset (LVR) ③ Power-on reset (POR) ④ Watchdog (WDT) reset.

7.3.1 EXTERNAL RST RESET

External reset is to supply a certain width reset pulse signal to the SC92F732X from the RST pin to realize the SC92F732X reset.

The RST/INT01/P1.1 can be used as RST (reset pin) when the SC92F732X power – on, the user can configure P1.1 as non-reset pin in Customer Option via PC programme software before programming. When the RST/INT01/P1.1 pin is configured as non-reset pin, the pin has no reset function when SC92F732X is in normal operation, but it is still used as a reset pin when power is supplied. Therefore, the user should avoid pulling down the RST/INT01/P1.1 pin when power is on, otherwise the MCU will enter the reset state and cannot run the program normally.

7.3.2 LOW-VOLTAGE RESET LVR

The SC92F732X provides a low-voltage reset circuit. There are 4-level LVR voltage options: 4.3V, 3.7V, 2.9V and 2.3V. The default is the Option value written by user.

OP_CTM0 (C1H@FFH) Customer Option Register 0 (Read/Write)

Bit Number	7	6	5	4	3	2	1	0
Bit Symbol	ENWDT	ENXTL	SCLKS[1: 0]		DISRST	DISLVR	LVRS[1: 0]	
R/W	R/W	R/W	R/W		R/W	R/W	R/W	
POR	n	n	N		n	n	n	

Bit Number	Bit Symbol	Description
2	DISLVR	LVR control bit 0: LVR valid 1: LVR invalid
1 ~ 0	LVRS [1: 0]	LVR voltage selection bits 11: 4.3 V reset 10: 3.7 V reset 01: 2.9 V reset 00: 2.3 V reset

The Circuit Diagram of the SC92F732X Resetting Part is shown below:

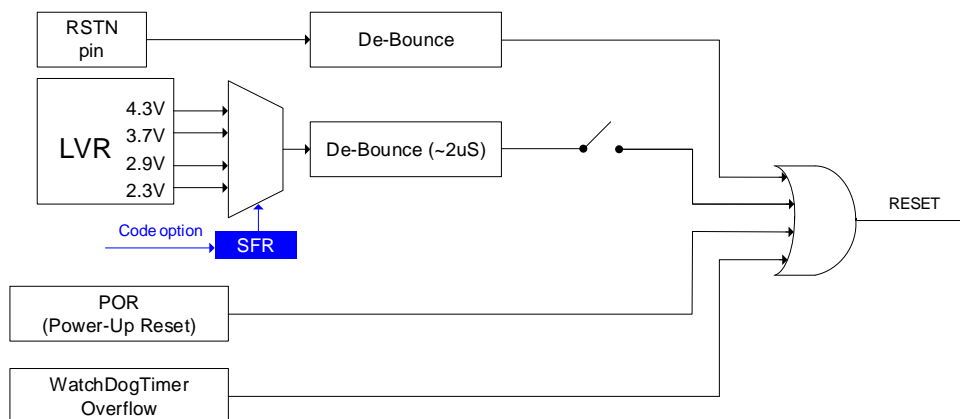

The SC92F732X Reset Circuit Diagram

7.3.3 POWER-ON RESET (POR)

The SC92F732X provides a power-on reset circuit. When power voltage V_{DD} is up to POR reset voltage, the system will be reset automatically.

7.3.4 WATCHDOG RESET (WDT)

The SC92F732X has a WDT, the clock source of which is the internal 2 kHz oscillator. User can select whether to enable Watchdog Reset function by programmer Code Option.

OP_CTM0 (C1H@FFH) Customer Option Register 0 (Read/Write)

Bit Number	7	6	5	4	3	2	1	0
Bit Symbol	ENWDT	ENXTL	SCLKS[1: 0]		DISRST	DISLVR	LVRS[1: 0]	
R/W	R/W	R/W	R/W		R/W	R/W	R/W	
POR	n	n	n		n	n	n	

Bit Number	Bit Symbol	Description
7	ENWDT	WDT control bit (This bit is transferred by the system to the value set by the user Code Option) 1: WDT valid 0: WDT invalid

WDTCON (CFH) WDT Control Register (Read/Write)

Bit Number	7	6	5	4	3	2	1	0
Bit Symbol	-	-	-	CLRWDT	-	WDTCKS[2: 0]		
R/W	-	-	-	R/W	-	R/W		
POR	x	x	x	0	x	0	0	0

Bit Number	Bit Symbol	Description																		
4	CLRWDT	Clear WDT (Only valid when set to 1) 1: WDT counter restart, cleared by system hardware																		
2 ~ 0	WDTCKS [2: 0]	WDT clock selection bits <table border="1" data-bbox="614 555 1182 1413"> <thead> <tr> <th>WDTCKS[2: 0]</th> <th>WDT overflow time</th> </tr> </thead> <tbody> <tr> <td>000</td> <td>500ms</td> </tr> <tr> <td>001</td> <td>250ms</td> </tr> <tr> <td>010</td> <td>125ms</td> </tr> <tr> <td>011</td> <td>62.5ms</td> </tr> <tr> <td>100</td> <td>31.5ms</td> </tr> <tr> <td>101</td> <td>15.75ms</td> </tr> <tr> <td>110</td> <td>7.88ms</td> </tr> <tr> <td>111</td> <td>3.94ms</td> </tr> </tbody> </table>	WDTCKS[2: 0]	WDT overflow time	000	500ms	001	250ms	010	125ms	011	62.5ms	100	31.5ms	101	15.75ms	110	7.88ms	111	3.94ms
WDTCKS[2: 0]	WDT overflow time																			
000	500ms																			
001	250ms																			
010	125ms																			
011	62.5ms																			
100	31.5ms																			
101	15.75ms																			
110	7.88ms																			
111	3.94ms																			
7 ~ 5, 3	-	Reserved																		

7.3.5 RESET INITIAL STATE

During reset, most registers are set to their initial values and the WDT remains disable. The initial value of stack pointer SP is 07h. Reset of “Hot Start” (such as WDT, LVR, etc.) will not influence SRAM which always keep the value before resetting. The SRAM contents will be retained until the power voltage is too low to keep RAM alive.

The initial value of power-on reset in SFRs is shown in the table below:

SFR Name	POR	SFR Name	POR
ACC	00000000b	P0PH	00000000b

B	00000000b	P0VO	xxx00000b
PSW	00000000b	P1	00000000b
SP	00000111b	P1CON	00000000b
DPL	00000000b	P1PH	00000000b
DPH	00000000b	P2	00000000b
PCON	0xxxxx00b	P2CON	00000000b
ADCCFG0	00000000b	P2PH	00000000b
ADCCFG1	xxxxxx00b	P5	xxxxxx00b
ADCCON	00000000b	P5CON	xxxxxx00b
ADCVH	00000000b	P5PH	xxxxxx00b
ADCVL	0000xxxxb	PWMCFG	xx000000b
BTMCON	00xxx000b	PWMCON	00000000b
IAPADE	00000000b	PWMDTYA	xx000000b
IAPADH	xxx00000b	PWMDTY0	00000000b
IAPADL	00000000b	PWMDTY1	00000000b
IAPCTL	xxx00000b	PWMDTY2	00000000b
IAPDAT	00000000b	PWMPRD	00000000b
IAPKEY	00000000b	RCAP2H	00000000b
IE	00000000b	RCAP2L	00000000b

IE1	xxxx000xb	SBUF	00000000b
INT0R	xxxx0000b	SCON	00000000b
INT1R	xxxx0000b	TCON	0000xxxxb
INT2R	xx000000b	TMCON	xxxxx000b
INT0F	xxxx0000b	TMOD	x000x000b
INT1F	xxxx0000b	TH0	00000000b
INT2F	xx000000b	TL0	00000000b
IP	x0000000b	TH1	00000000b
IP1	xxxx000xb	TL1	00000000b
OTCON	xxxx00xxb	T2CON	00000000b
OPINX	00000000b	TH2	00000000b
OPREG	nnnnnnnnb	TL2	00000000b
IOHCON	00000000b	T2MOD	xxxxxx00b
P0	00000000b	WDTCN	xxx0x000b
P0CON	00000000b	-	-

7.4 High-speed RC Oscillator Circuit

The SC92F732X has a built-in adjustable high-precision HRC. HRC is precisely calibrated to 24 MHz@5V/25°C when delivery. The user can set system clock as 24/12/6/2MHz by programmer Code Option. The calibration process is to filter the influence of processing deviation on precision. There will be certain drifting of this HRC depending on operating temperature and voltage. As for voltage drifting (4.5V ~ 5.5V) and temperature drifting (-20°C ~ 85°C), the deviation is within $\pm 1\%$.

OP_CTM0 (C1H@FFH) Customer Option Register 0 (Read/Write)

Bit Number	7	6	5	4	3	2	1	0
Symbol	ENWDT	ENXTL	SCLKS[1: 0]		DISRST	DISLVR	LVRS[1: 0]	
R/W	R/W	R/W	R/W		R/W	R/W	R/W	
POR	n	n	n		n	n	n	

Bit Number	Bit Symbol	Description
5 ~ 4	SCLKS[1: 0]	System clock frequency selection bits: 00: reserved; System clock frequency is HRC frequency divided by 1, only valid when ENXTL=0; 01: system clock frequency is HRC frequency divided by 2; 10: system clock frequency is HRC frequency divided by 4; 11: system clock frequency is HRC frequency divided by 12;

The SC92F732X has a special function: the user can modify SFR value to adjust frequency of HRC within certain scope.

OP_HRCR (83h@FFH) System Clock Change Register (Read/Write)

Bit Number	7	6	5	4	3	2	1	0
Bit Symbol	OP_HRCR[7: 0]							
R/W	R/W							
POR	n	n	n	n	n	n	n	n

Bit Number	Bit Symbol	Description
7 ~ 0	OP_HRCR[7: 0]	HRC frequency change register

The value of OP_HRCR[7:0] after power-on guarantee HRC is 24/12/6/2MHz (according to the user's choice of Code Option). There may be difference in OP_HRCR[s] of each IC. The user can change the HRC operating frequency by modifying the value of this register.

When initial value is OP_HRCR[s], IC system clock frequency f_{SYS} can set specifically as 24/12/6/2MHz. For each change of 1 for OP_HRCR [7: 0], the change of HRC frequency is about 0.23%@12MHz.

The relationship between OP_HRCR [7: 0] and output frequency HRC is shown as follows:

OP_HRCR [7:0]	f_{SYS} actual output frequency (taking 12M as an example)
OP_HRCR [s]-n	$12000 * (1 - 0.23\% * n)$ kHz
...
OP_HRCR [s]-2	$12000 * (1 - 0.23\% * 2) = 11944.8$ kHz
OP_HRCR [s]-1	$12000 * (1 - 0.23\% * 1) = 11972.4$ kHz
OP_HRCR [s]	12000 kHz
OP_HRCR [s]+1	$12000 * (1 + 0.23\% * 1) = 12027.6$ kHz
OP_HRCR [s]+2	$12000 * (1 + 0.23\% * 2) = 12055.2$ kHz
...	...
OP_HRCR [s]+n	$12000 * (1 + 0.23\% * n)$ kHz

Note:

1. The value of OP_HRCR[7:0] after each power-on of the IC is the value of high-frequency oscillator frequency f_{HRC} closest to 24MHz; the user can modify the value of HRC after each power-on by means of EEPROM to make IC system clock frequency f_{SYS} work at the frequency the user needs.
2. To guarantee IC operating reliably, the maximum operating frequency of IC shall not exceed 24MHz;
3. The user shall confirm the change of HRC frequency will not influence other functions.

7.5 Low-speed RC Oscillator and Low-speed Clock Timer

The SC92F732X is equipped with a built-in 128kHz RC oscillation circuit and a 32.768kHz crystal oscillation circuit, which can be set as clock source of low-frequency clock timer Base Timer. This oscillator is directly connected to Base Timer, which can wake up CPU from STOP mode and generate interrupt.

BTMCON (CEH) Low-Frequency Timer Control Register (Read/Write)

Bit Number	7	6	5	4	3	2	1	0
Bit Symbol	ENBTM	BTMIF	-	-		BTMFS[2: 0]		
R/W	R/W	R/W	-	-		R/W		
POR	0	0	x	x	0		0	0

Bit Number	Bit Symbol	Description
7	ENBTM	Low-frequency Base Timer start control bit 0: 128kHz LRC/32K crystal and the low-frequency Base Timer not start 1: 128kHz LRC/32K crystal and the low-frequency Base Timer start
6	BTMIF	Base Timer interrupt application flag bit When CPU receives Base Timer interrupt, this flag will be cleared automatically by hardware. The user can clear it by software.
2 ~ 0	BTMFS [2: 0]	Low-frequency clock interrupt frequency selection bits 000: an interrupt is generated for every 15.625ms 001: an interrupt is generated for every 31.25ms 010: an interrupt is generated for every 62.5ms 011: an interrupt is generated for every 125ms 100: an interrupt is generated for every 0.25s 101: an interrupt is generated for every 0.5s

		110: an interrupt is generated for every 1.0s 111: an interrupt is generated for every 2.0s
5 ~ 3	-	Reserved

OP_CTM0 (C1h@FFH) Customer Option Register0 (Read/Write)

Bit Number	7	6	5	4	3	2	1	0
Bit Symbol	ENWDT	ENXTL	SCLKS[1:0]	DISRST	DISLVR	LVRS[1:0]		
R/W	R/W	R/W	R/W	R/W	R/W	R/W		
POR	n	n	n	n	n	n	n	n

Bit Number	Bit Symbol	Description
6	ENXTL	External 32KHz crystal option 0: External 32KHz crystal unenabled,P5.0, P5.1 valid and internal LRC invalid. 1: External 32KHz crystal enabled,P5.0, P5.1 invalid and internal LRC invalid.

The circuit diagram of the P5.0/P5.1 connect external 32KHz crystal as the Base Timer as follows:

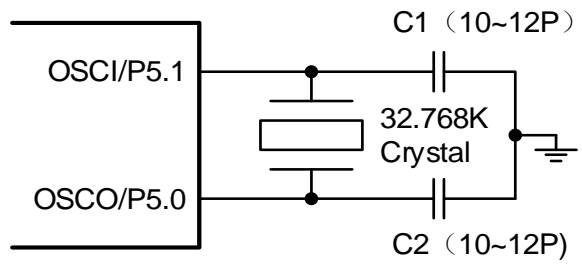

32KHz external crystal connecting circuit diagram

The selection relation diagram of internal and external oscillations of the Base Timer is as follows:

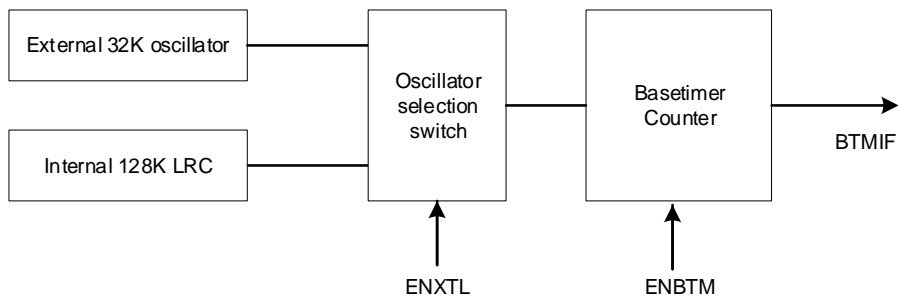

Base Timer block

7.6 STOP Mode and IDLE Mode

The SC92F732X provides a SFR PCON, the user can configure bit 0 and bit 1 of this register to control MCU to enter different operating modes.

When PCON.1 = 1, internal high-frequency system clock would stop and system enter STOP mode, to save power. The system can be woken up from STOP by external interrupt INT0 ~ INT2, low-frequency clock interrupt, and external reset input.

When PCON.0 = 1, the programme would stop running and System enter IDLE mode. But the external equipment and clock will continue running, CPU will keep all states before entering IDLE mode. The system can be woken up from IDLE by any interrupt.

PCON (87H) Power Management Control Register (only for write, *unreadable*)

Bit Number	7	6	5	4	3	2	1	0
Bit Symbol	SMOD	-	-	-	-	-	STOP	IDL
R/W	W	-	-	-	-	-	W	W
POR	0	x	x	x	x	x	0	0

Bit Number	Bit Symbol	Description
1	STOP	STOP mode control bit 0: normal operating mode 1: stop mode, high-frequency oscillator stops operating, low-frequency

		oscillator and WDT can select to work based on configuration
0	IDL	<p>IDLE mode control bit</p> <p>0: normal operating mode</p> <p>1: IDLE mode, the program stops operating, but external equipment and clock continue to operate and all CPU states are saved before entering IDLE mode</p>

Notes: When Configure MCU to enter STOP or IDLE mode, the instruction of configuring PCON register should be followed by 4 “NOP” instructions rather than other instructions. Or else, it will be unable to execute following instructions normally after wake-up!

For example, configure MCU to enter STOP mode:

C program example:

```
#include"intrins.h"

PCON |= 0x02;          //Set to 1 for PCON bit1 STOP bit, configure MCU to enter STOP mode

_nop_ ();              //At least 4 _nop_ () required

_nop_ ();

_nop_ ();

_nop_ ();

.....
```

Assembly program example:

```
ORL PCON, #02H        ; Set to 1 for PCON bits1 STOP bit, configure MCU to enter STOP mode

NOP                    ; At least 4 NOP required

NOP

NOP

NOP

.....
```

8 CPU AND FUNCTION SYSTEM

8.1 CPU

CPU used by the SC92F732X is the high-speed 1T standard 8051 core, whose instructions are completely compatible with traditional 8051 core microcontroller unit.

8.2 Addressing Mode

The addressing mode of the SC92F732X 1T 8051 CPU instructions includes: ① Immediate Addressing ② Direct Addressing ③ Indirect Addressing ④ Register Addressing ⑤ Relative Addressing ⑥ Indexed Addressing ⑦ Bit Addressing

8.2.1 IMMEDIATE ADDRESSING

Immediate addressing is also called immediate operand addressing, which is the operand given to participate in operation in instruction, the instruction is illustrated as follows:

MOV A, #50H (This instruction is to move immediate operand 50H to Accumulator A)

8.2.2 DIRECT ADDRESSING

In direct addressing mode, the instruction operand field indicates the address to participate in operation operand. Direct addressing can only be used to address SFRs, internal data registers and bit address space. The SFRs and bit address space can only be accessed by direct addressing. For example:

ANL 50H, #91H (The instruction indicates the data in 50H unit AND immediate operand 91H, and the results are stored in 50H unit. 50H refers to direct address, indicating one unit in internal data register RAM.)

8.2.3 INDIRECT ADDRESSING

Indirect addressing is expressed as adding "@" before R0 or R1. Suppose the data in R1 is 40H and the data of internal data register 40H unit is 55H, then the instruction will be

MOV A, @R1 (Move the data 55h to Accumulator A).

8.2.4 REGISTER ADDRESSING

Register addressing is to operate the data in the selected registers R7 ~ R0, Accumulator A, general-purpose register B, address registers and carry bit C. The registers R7-R0 is indicated by lower 3 bits of instruction code. ACC, B, DPTR and carry bit C are implied in the instruction code. Therefore, register addressing can also include an implied addressing mode. The selection of register operating area depends on RS1 and RS0 of PSW. The registers indicated by instruction operand refers to the registers in current operating area.

INC R0 refers to (R0) +1 → R0

8.2.5 RELATIVE ADDRESSING

Relative addressing is to add current value in program counter (PC) and the data in the second byte of the instruction, whose result shall be taken as the jump address of jump instruction. The Jump address is the target jump address, the current value in PC is the base address and the data in the second byte of the instruction is the offset address. Because the target jump address is relative to base address in PC, such addressing mode is called relative addressing. The offset is signed number, which ranges from +127 to -128, such addressing mode is mainly applied to jump instruction.

JC \$+50H

It indicates that if the carry bit C is 0, the contents in program counter PC remain the same, meaning no jump. On

the contrary, if the carry bit C is 1, take the sum of the current value in PC and base address as well as offset 50H as the target jump address of this jump instruction.

8.2.6 INDEXED ADDRESSING

In indexed addressing mode, the instruction operand is to develop an indexed register to store indexed base address. Upon indexed addressing, the result by adding offset and indexed base address is taken as the address of operation operand. The indexed registers include PC and address register DPTR.

```
MOVC A, @A+DPTR
```

It indicates Accumulator A is used as offset register. Take the sum of the value in A and that in the address register DPTR as the address of operand. Then take the figure in the address out and transmit it to Accumulator A.

8.2.7 BITS ADDRESSING

Bit addressing is a kind of addressing mode when conducting bit operation on internal data storage RAM and SFRs which are able to carry out bit operations. Upon bit operations, by taking carry bit C as bit operation accumulator, the instruction operand will give the address of this bit directly, then execute bit operation based on the nature of operation code.

```
MOV C, 20H (Transmit the bit operation register with address of 20H into carry bit C)
```

9 INTERRUPT

The SC92F732X provides 10 interrupt sources: Timer0, Timer1, Timer2, INT0 ~ 2, ADC, PWM, UART and Base Timer. These 10 interrupt sources are equipped with 2-level interrupt priority-capability and each interrupt source can be individually configured in high priority or low priority. As for three external interrupts, the triggering condition of each interrupt source can be set as rising edge, falling edge or dual-edge trigger. Each interrupt is equipped with independent priority setting bit, interrupt flag, interrupt vector and enable bit. Global interrupt enable bit EA can enable or disable all interrupts.

9.1 Interrupt Source and Vector

Lists for the SC92F732X interrupt source, interrupt vector and related control bit are shown below:

Interrupt Source	Interrupt condition	Interrupt Flag	Interrupt Enable Control	Interrupt Priority Control	Interrupt Vector	Query Priority	Interrupt Number (C51)	Flag Clear Mode	Capability of Waking up STOP
INT0	Compliant with External interrupt 0 conditions	IE0	EINT0	IPINT0	0003H	1 (high)	0	-	Yes
Timer0	Timer0 overflow	TF0	ET0	IPT0	000BH	2	1	H/W Auto	No
INT1	Compliant with External interrupt 1 conditions	-	EINT1	IPINT1	0013H	3	2	-	Yes
Timer1	Timer1	TF1	ET1	IPT1	001BH	4	3	H/W Auto	No

	overflow								
UART	Receiving or transmitting completed	RI/TI	EUART	IPUART	0023H	5	4	Must be cleared by user	No
Timer2	Timer2 overflow	TF2	ET2	IP2	002BH	6	5	Must be cleared by user	No
ADC	ADC conversion completed	ADCIF	EADC	IPADC	0033H	7	6	Must be cleared by user	No
PWM	PWM overflow	PWMIF	EPWM	IPPWM	0043H	8	8	H/W Auto	No
BTM	Base timer overflow	BTMIF	EBTM	IPBTM	004BH	9	9	H/W Auto	Yes
INT2	External interrupt 2 conditions compliant	-	EINT2	IPINT2	0053H	10	10	-	Yes

Under the circumstance where the master interrupt control bit EA and the respective interrupt control bit have been enable, the interrupt occurrence is shown below:

Timer Interrupt: Interrupt generates when Timer0 or Timer1 overflows and the interrupt flag TF0 or TF1 is set to “1”. When the microcontroller unit responds to the timer interrupt, the interrupt flag TF0 or TF1 is reset automatically by hardware. Interrupt generates when Timer2 overflows and the interrupt flag TF2 is set to “1”. Once Timer2 interrupt generates, the hardware would not automatically clear TF2 bit, which must be cleared by the user’s software.

UART Interrupt: When UART receive or transmit a frame of data, the RI or TI bit will be automatically set “1” by the hardware, and the UART interrupt will occur. Once the UART interrupt generates, the hardware would not automatically clear RI/TI bit ,which must be cleared by the user’s software.

ADC Interrupt: After ADC conversion is completed, ADC interrupt generates, whose interrupt flag is the ADC conversion completion flag EOC/ADCIF (ADCCON.5). When user starts ADCS conversion, EOC will be reset automatically by hardware. Once conversion completes, EOC would be set to “1” automatically by hardware. User should clear the ADC interrupt flag by software when the interrupt service routine is executed after ADC interrupt generates.

PWM Interrupt: When PWM counter overflows (beyond PWMPD), The PWMIF bit will be set to 1 automatically by hardware, PWM interrupt generates. When the microcontroller unit executes PWM interrupt, the interrupt sign PWMIF will be clear to “0” automatically by hardware.

External Interrupt INT0 ~ 2: When any external interrupt pin meets the interrupt conditions, external interrupt generates. There are 4 external interrupt sources for INT0 and INT1 and 6 external interrupt sources for INT2, which can be set in rising edge, falling edge or dual edge interrupt trigger mode by setting SFRs (INTxF and INTxR). User can set the priority level of each interrupt through IP register. Besides, external interrupt INT0 ~ 2 can also wake up STOP mode of microcontroller unit.

9.2 Interrupt Structure Diagram

The SC92F732X interrupt structure is shown in the figure below:

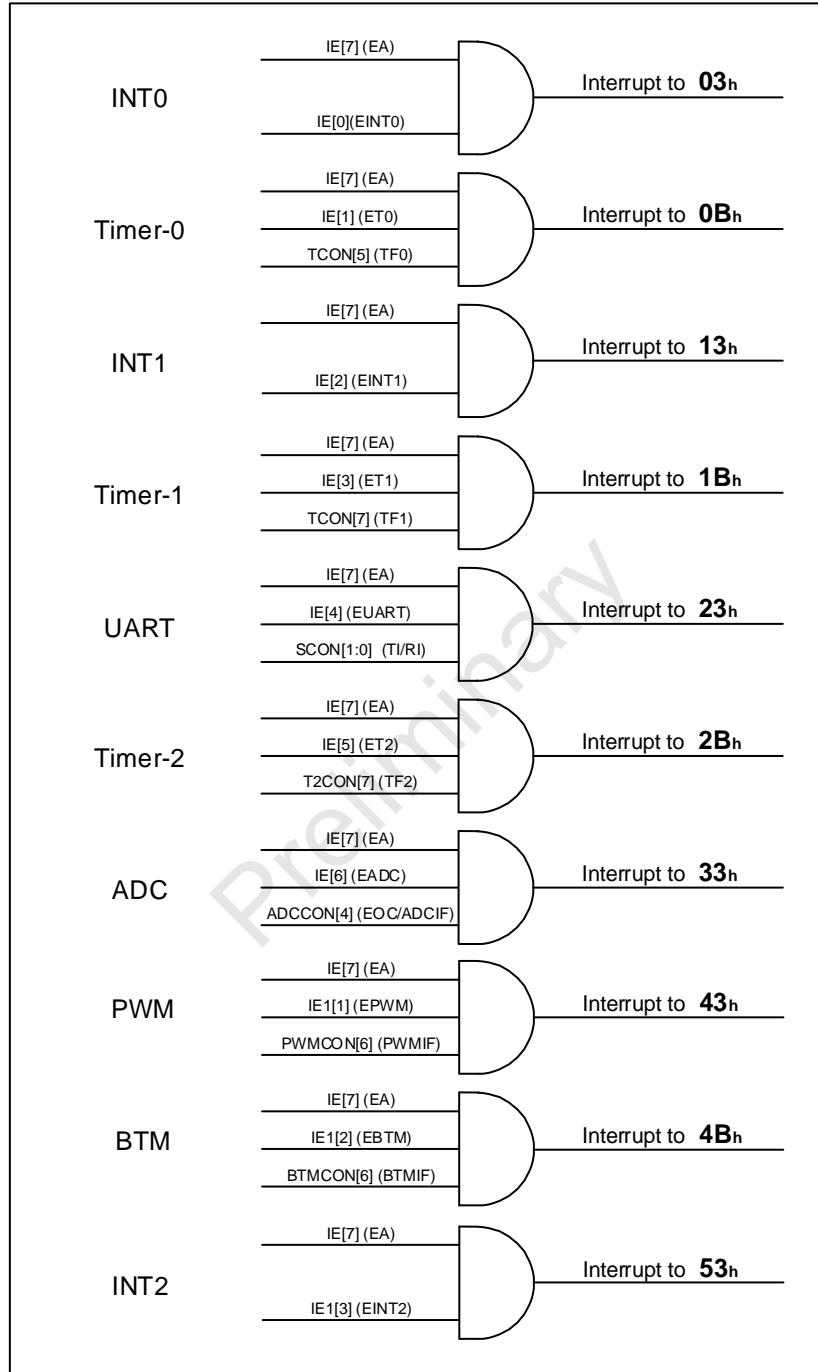

The SC92F732X Interrupt Structure and Vector

9.3 Interrupt Priority

The SC92F732X microcontroller unit has two-level interrupt priority capability. The interrupt requests of these interrupt sources can be programmed as high-priority interrupt or low-priority interrupt, which is to realize the nesting of two levels of interrupt service programs. One interrupt can be interrupted by a higher priority interrupt request when being responded to, which can not be interrupted by another interrupt request at the same priority level, until such response to the first-come interrupt ends up with the instruction "RETI". Exist the interrupt service routine and return to main program, the system would execute one more instruction before responding to new interrupt request.

That is to say:

- ① A lower priority interrupt can be interrupted by a higher priority interrupt request, but not vice versa;
- ② Any kind of interrupt being responded to can not be interrupted by another interrupt request at the same priority level.

Interrupt query sequence: As for the sequence of that the SC92F732X microcontroller unit responds to the same priority interrupts which occur in the meantime, the priority sequence of interrupt response shall be the same as the interrupt query number in C51, which is to preferentially respond to the interrupt with smaller query number then the interrupt with bigger query number.

9.4 Interrupt Processing Flow

When any interrupt generates and is responded by CPU, the operation of main program will be interrupted to carry out the following operations:

- ① Complete execution of instruction being currently executed;
- ② Push the PC value into stack for site protection;
- ③ Load Interrupt vector address into program counter (PC);
- ④ Carry out corresponding interrupt service program;
- ⑤ End Interrupt service program ends and execute RETI;
- ⑥ Pop PC value from stack and return to the program before responding to the interrupt.

During this process, the system will not immediately respond to other interrupts at the same priority level, but it will keep all interrupt requests having occurred and respond to new interrupt requests upon completing handling of the current interrupt.

9.5 Interrupt-related SFR Registers

IE (A8H) Interrupt Enable Register (Read/Write)

Bit Number	7	6	5	4	3	2	1	0
------------	---	---	---	---	---	---	---	---

Bit Symbol	EA	EADC	ET2	EUART	ET1	EINT1	ET0	EINT0
R/W	R/W	R/W	R/W	R/W	R/W	R/W	R/W	R/W
POR	0	0	0	0	0	0	0	0

Bit Number	Bit Symbol	Description
7	EA	Global interrupt enable control bit 0: Disable all interrupts 1: Enable all interrupts
6	EADC	ADC interrupt enable control bit 0: Disable ADC interrupts 1: Interrupt is allowed upon completing ADC conversion
5	ET2	Timer2 interrupt enable control bit 0: Disable Timer2 interrupt 1: Enable Timer2 interrupt
TONG4	EUART	UART interrupt enable control bit 0: Disable UART interrupt 1: Enable UART interrupt
3	ET1	Timer1 interrupt enable control bit 0: Disable Timer1 interrupt 1: Enable Timer1 interrupt
2	EINT1	External interrupt 1 enable control 0: Disable INT1 interrupt 1: Enable INT1 interrupt
1	ET0	Timer0 interrupt enable control bit

		0: Disable Timer0 interrupt 1: Enable Timer0 interrupt
0	EINT0	External interrupt 0 enable control bit 0: Disable INT0 interrupt 1: Enable INT0 interrupt

IP (B8H) Interrupt Priority Control Register (Read/Write)

Bit Number	7	6	5	4	3	2	1	0
Bit Symbol	-	IPADC	IPT2	IPUART	IPT1	IPINT1	IPT0	IPINT0
R/W	-	R/W	R/W	R/W	R/W	R/W	R/W	R/W
POR	x	0	0	0	0	0	0	0

Bit Number	Bit Symbol	Description
6	IPADC	ADC interrupt priority selection bit 0: ADC interrupt priority is low 1: ADC interrupt priority is high
5	IPT2	Timer2 interrupt priority selection bit 0: Timer2 interrupt priority is low 1: Timer2 interrupt priority is high
4	IPUART	UART interrupt priority selection bit 0: UART interrupt priority is low 1: UART interrupt priority is high
3	IPT1	Timer1 interrupt priority selection bit 0: Timer1 interrupt priority is low 1: Timer1 interrupt priority is high

2	IPINT1	INT1 interrupt priority selection bit 0: INT1 interrupt priority is low 1: INT1 interrupt priority is high
1	IPT0	Timer 0 interrupt priority selection bit 0: Timer0 interrupt priority is low 1: Timer0 interrupt priority is high
0	IPINT0	INT0 interrupt priority selection bit 0: INT0 interrupt priority is low 1: INT0 interrupt priority is high
7	-	Reserved

IE1 (A9H) Interrupt Enable Register 1 (Read/Write)

Bit Number	7	6	5	4	3	2	1	0
Bit Symbol	-	-	-	-	EINT2	EBTM	EPWM	-
R/W	-	-	-	-	R/W	R/W	R/W	-
POR	x	x	x	x	0	0	0	x

Bit Number	Bit Symbol	Description
3	EINT2	External interrupt 2 enabling control bit 0: Disable External interrupt 2 1: Enable External interrupt 2
2	EBTM	Base Timer interrupt enabling control bit 0: Disable Base Timer interrupt 1: Enable Base Timer interrupt

1	EPWM	PWM interrupt enabling control bit 0: Disable PWM interrupt 1: Enable interrupt upon PWM counting overflows (counting to PWMPRD)
7 ~ 4,0	-	Reserved

IP1 (B9H) Interrupt Priority Control Register 1 (Read/Write)

Bit Number	7	6	5	4	3	2	1	0
Bit Symbol	-	-	-	-	IPINT2	IPBTM	IPPWM	-
R/W	-	-	-	-	R/W	R/W	R/W	-
POR	x	x	x	x	0	0	0	x

Bit Number	Bit Symbol	Description
3	IPINT2	INT2 interrupt priority selection bit 0: INT2 interrupt priority is low 1: INT2 interrupt priority is high
2	IPBTM	Base Timer interrupt priority selection bit 0: Base Timer interrupt priority is low 1: Base Timer interrupt priority is high
1	IPPWM	PWM interrupt priority selection bit 0: PWM interrupt priority is low 1: PWM interrupt priority is high
7 ~ 4,0	-	Reserved

INT0F (BAH) INT0 Falling Edge Interrupt Control Register (Read/Write)

Bit Number	7	6	5	4	3	2	1	0
Bit Symbol	-	-	-	-	INT0F3	INT0F2	INT0F1	INT0F0
R/W	-	-	-	-	R/W	R/W	R/W	R/W
POR	x	x	x	x	0	0	0	0

Bit Number	Bit Symbol	Description
3 ~ 0	INT0Fn (n=0 ~ 3)	INT0 falling edge interrupt control bit 0: INT0n falling edge interrupt off 1: INT0n falling edge interrupt enabling
7 ~ 4	-	Reserved

INT0R (BBH) INT0 Rising Edge Interrupt Control Register (Read/Write)

Bit Number	7	6	5	4	3	2	1	0
Bit Symbol	-	-	-	-	INT0R3	INT0R2	INT0R1	INT0R0
R/W	-	-	-	-	R/W	R/W	R/W	R/W
POR	x	x	x	x	0	0	0	0

Bit Number	Bit Symbol	Description
3 ~ 0	INT0Rn (n=0 ~ 3)	INT0 rising edge interrupt control bit 0: INT0n rising edge interrupt off 1: INT0n rising edge interrupt enabling

7 ~ 4	-	Reserved
-------	---	----------

INT1F (BCH) INT1 Falling Edge Interrupt Control Register (Read/Write)

Bit Number	7	6	5	4	3	2	1	0
Bit Symbol	-	-	-	-	INT1F3	INT1F2	INT1F1	INT1F0
R/W	-	-	-	-	R/W	R/W	R/W	R/W
POR	x	x	x	x	0	0	0	0

Bit Number	Bit Symbol	Description
3 ~ 0	INT1Fn (n=0 ~ 3)	INT1 falling edge interrupt control bit 0: INT1n falling edge interrupt off 1: INT1n falling edge interrupt enabling
7 ~ 4	-	Reserved

INT1R (BDH) INT1 Rising Edge Interrupt Control Register (Read/Write)

Bit Number	7	6	5	4	3	2	1	0
Bit Symbol	-	-	-	-	INT1R3	INT1R2	INT1R1	INT1R0
R/W	-	-	-	-	R/W	R/W	R/W	R/W
POR	x	x	x	x	0	0	0	0

Bit Number	Bit Symbol	Description
3 ~ 0	INT1Rn	INT1 rising edge interrupt control bit

	(n=0 ~ 3)	0: INT1n rising edge interrupt off 1: INT1n rising edge interrupt enabling
7 ~ 4	-	Reserved

INT2F (C6H) INT2 Falling Edge Interrupt Control Register (Read/Write)

Bit Number	7	6	5	4	3	2	1	0
Bit Symbol	-	-	INT2F5	INT2F4	INT2F3	INT2F2	INT2F1	INT2F0
R/W	-	-	R/W	R/W	R/W	R/W	R/W	R/W
POR	x	x	0	0	0	0	0	0

Bit Number	Bit Symbol	Description
5 ~ 0	INT2Fn (n=0 ~ 5)	INT2 falling edge interrupt control bit 0: INT2n falling edge interrupt off 1: INT2n falling edge interrupt enabling
7 ~ 6	-	Reserved

INT2R (C7H) INT2 Rising Edge Interrupt Control Register (Read/Write)

Bit Number	7	6	5	4	3	2	1	0
Bit Symbol	-	-	INT2R5	INT2R4	INT2R3	INT2R2	INT2R1	INT2R0
R/W	-	-	R/W	R/W	R/W	R/W	R/W	R/W
POR	x	x	0	0	0	0	0	0

Bit Number	Bit Symbol	Description
5 ~ 0	INT2Rn (n=0 ~ 5)	INT2 rising edge interrupt control bit 0: INT2n rising edge interrupt off 1: INT2n rising edge interrupt enabling
7 ~ 6	-	Reserved

10 TIMER / EVENT COUNTER TIMER0 AND TIMER1

The SC92F732X has two 16-bit Timer/Counters, Timer0 (T0) and Time1 (T1), with two operating modes: counter mode and timer mode. The operating modes selected by bit C/Tx in the SFR TMOD. T0 and T1 are essentially adding counters with different counting source. The source of timer generated from system clock or frequency division clock, but the source of counters is the input pulse to external pin. Only when TRx = 1, will T0 and T1 be enabled on for counting.

In counter mode, each input pulse on P1.2/T0 and P1.3/T1 pin will make the count value of T0 and T1 increase by 1 respectively.

In timer mode, users can select $f_{SYS}/12$ or f_{SYS} (f_{SYS} is the system clock after frequency division) as counting source of T0 and T1 by configuring SFR TMCON.

Timer/Counter T0 has 4 operating modes, and Timer/Counter T1 has 3 operating modes (Mode 3 does not exist):

- ① Mode 0: 13-bit Timer/Counter mode
- ② Mode 1: 16-bit Timer/Counter mode
- ③ Mode 2: 8-bit automatic reload mode
- ④ Mode 3: Two 8-bit timers/counters mode

In above modes, modes 0, 1 and 2 of T0 and T1 are the same, and mode 3 is different.

10.1 T0 and T1-related Special function Registers

Symbol	Address	Function	7	6	5	4	3	2	1	0	Reset Value
TCON	88H	Timer Control Register	TF1	TR1	TF0	TR0	-	-	-	-	0000xxxxb
TMOD	89H	Timer Operating Mode Register	-	C/T1	M11	M01	-	C/T0	M10	M00	x000x000b
TL0	8AH	Timer0 Low byte	TL0[7: 0]								00000000b

TL1	8BH	Timer1 Low byte	TL1[7: 0]							00000000b		
TH0	8CH	Timer0 High byte	TH0[7: 0]							00000000b		
TH1	8DH	Timer1 High byte	TH1[7: 0]							00000000b		
TMCON	8EH	Timer Frequency Control Register	-	-	-	-	-	T2FD	T1FD	T0FD	xxxxx000b	

Register instructions are shown below:

TCON (88H) Timer Control Register (Read/Write)

Bit Number	7	6	5	4	3	2	1	0
Bit Symbol	TF1	TR1	TF0	TR0	-	-	-	-
R/W	R/W	R/W	R/W	R/W	-	-	-	-
POR	0	0	0	0	X	x	x	x

Bit Number	Bit Symbol	Description
7	TF1	Timer1 overflow flag bit Set by hardware on Timer/Counter overflow. Cleared by hardware when the processor vectors to interrupt routine.
6	TR1	Timer1 run control bit Set/cleared by software to turn Timer/Counter on/off.
5	TF0	Timer0 overflow flag bit Set by hardware on Timer/Counter overflow. Cleared by hardware when the processor vectors to interrupt routine.
4	TR0	Timer0 run control bit Set/cleared by software to turn Timer/Counter on/off.
2, 0	-	Reserved

TMOD (89H) Timer Operating Mode Register (Read/Write)

Bit Number	7	6	5	4	3	2	1	0
Bit Symbol	-	C/T1	M11	M01	-	C/T0	M10	M00
R/W	-	R/W	R/W	R/W	-	R/W	R/W	R/W
POR	x	0	0	0	x	0	0	0
	T1				T0			

Bit Number	Bit Symbol	Description																				
6	C/T1	Timer or Counter selector 1 0: Cleared for Timer operation (input from internal system clock fsys). 1: Set for Counter operation (input from external pin T1/P1.3).																				
5 ~ 4	M11, M01	Timer1 operating mode <table border="1"> <thead> <tr> <th>Mode</th> <th>M11</th> <th>M01</th> <th>Operation</th> </tr> </thead> <tbody> <tr> <td>0</td> <td>0</td> <td>0</td> <td>13-bit TIMER/Counter, TL1 high 3 bits invalid</td> </tr> <tr> <td>1</td> <td>0</td> <td>1</td> <td>16-bit Timer/Counter</td> </tr> <tr> <td>2</td> <td>1</td> <td>0</td> <td>8-bit Auto-Reload Mode. TH1 holds a value which is reloaded into 8-bit Timer/Counter TL1 each time it overflows.</td> </tr> <tr> <td>3</td> <td>1</td> <td>1</td> <td>Timer/Counter 1 is stopped</td> </tr> </tbody> </table>	Mode	M11	M01	Operation	0	0	0	13-bit TIMER/Counter, TL1 high 3 bits invalid	1	0	1	16-bit Timer/Counter	2	1	0	8-bit Auto-Reload Mode. TH1 holds a value which is reloaded into 8-bit Timer/Counter TL1 each time it overflows.	3	1	1	Timer/Counter 1 is stopped
Mode	M11	M01	Operation																			
0	0	0	13-bit TIMER/Counter, TL1 high 3 bits invalid																			
1	0	1	16-bit Timer/Counter																			
2	1	0	8-bit Auto-Reload Mode. TH1 holds a value which is reloaded into 8-bit Timer/Counter TL1 each time it overflows.																			
3	1	1	Timer/Counter 1 is stopped																			
2	C/T0	Timer or Counter selector 0 0: Cleared for Timer operation (input from internal system clock fsys). 1: Set for Counter operation (input from external pin T1/P1.2).																				

1 ~ 0	M10, M00	Timer0 operating mode			
		Mode	M10	M00	Operation
		0	0	0	13-bit TIMER/Counter, TL0 high 3 bits invalid
		1	0	1	16-bit Timer/Counter
		2	1	0	8-bit Auto-Reload Mode. TH0 holds a value which is reloaded into 8-bit Timer/Counter TL0 each time it overflows.
3	1	1	Split Timer Mode. TL0 is an 8-bit Timer/Counter controlled by the standard Timer0 control bits. TH0 is only an 8-bit timer controlled by Timer1 control bits		
7, 3	-	Reserved			

TMOD[0] ~ TMOD[2] of TMOD register is to set operating mode of T0; TMOD[4] ~ TMOD[6] is to set the operating mode of T1.

The function of timer and counter Tx is selected by the control bit C/Tx of SFR TMOD, and it's operating mode selected by M0x and M1x. Only when TRx, the switch of T0 and T1, is set to 1, will T0 and T1 be enabled

TMCON (8EH) Timer Frequency Control Register (Read/Write)

Bit Number	7	6	5	4	3	2	1	0
Bit Symbol	-	-	-	-	-	T2FD	T1FD	T0FD
R/W	-	-	-	-	-	R/W	R/W	R/W
POR	x	x	x	x	x	0	0	0

Bit Number	Bit Symbol	Description
1	T1FD	T1 input frequency selection control bit 0: T1 clock source is $f_{SYS}/12$ 1: T1 clock source is f_{SYS}
0	T0FD	T0 input frequency selection control bit 0: T0 clock source is $f_{SYS}/12$ 1: T0 clock source is f_{SYS}

IE (A8H) Interrupt Enable Register (Read/Write)

Bit Number	7	6	5	4	3	2	1	0
Bit Symbol	EA	EADC	ET2	EUART	ET1	EINT1	ET0	EINT0
R/W	R/W	R/W	R/W	R/W	R/W	R/W	R/W	R/W
POR	0	0	0	0	0	0	0	0

Bit Number	Bit Symbol	Description
3	ET1	Timer1 interrupt enable control bit 0: Disable Timer1 interrupt 1: Enable Timer1 interrupt
1	ET0	Timer0 interrupt enable control bit 0: Disable Timer0 interrupt 1: Enable Timer0 interrupt

IP (B8H) Interrupt Priority Control Register (Read/Write)

Bit Number	7	6	5	4	3	2	1	0
Bit Symbol	-	IPADC	IPT2	IPUART	IPT1	IPINT1	IPT0	IPINT0
R/W	-	R/W	R/W	R/W	R/W	R/W	R/W	R/W
POR	x	0	0	0	0	0	0	0

Bit Number	Bit Symbol	Description
3	IPT1	Timer1 interrupt priority selection bit 0: Configure Timer1 interrupt priority as "low" 1: Configure Timer1 interrupt priority as "high"
1	IPT0	Timer0 interrupt priority selection bit 0: Configure Timer0 interrupt priority as "low" 1: Configure Timer0 interrupt priority as "high"

10.2 T0 Operating Mode

Timer0 can be configured in one of four operating modes by setting the bit pairs (M10, M00) in the TMOD register.

Operating mode 0: 13-bit Timer/Counter

TH0 register is to store the high 8 bits (TH0.7 ~ TH0.0) of 13-bit Timer/Counter and TL0 is to store the low 5 bits (TL0.4 ~ TL0.0). The high three bits of TL0 (TL0.7 ~ TL0.5) are filled with uncertain values, they shall be omitted upon reading. When 13-bit Timer/Counter overflows with count increment, the system will set timer overflow flag TF0 to 1. An interrupt will be generated if the timer0 interrupt is enabled.

C/T0 bit selects the clock input source of Timer/Counter. If C/T0=1, the level fluctuation from high to low of Counter 0 input pin T0 (P1.2) will make Counter 0 data register add 1. If C/T0=0, the frequency division of system clock is the clock source of Timer0.

When TR0 = 1, Timer 0 is enabled. Setting TR0 would not reset the timer forcibly. It means that the timer register will start to count from the value of last clearing of TR0. Therefore, before enable the timer, it is required to configure the initial value of timer register.

When configured as a timer, the SFR T0FD is used to select fractional frequency ratio of clock source.

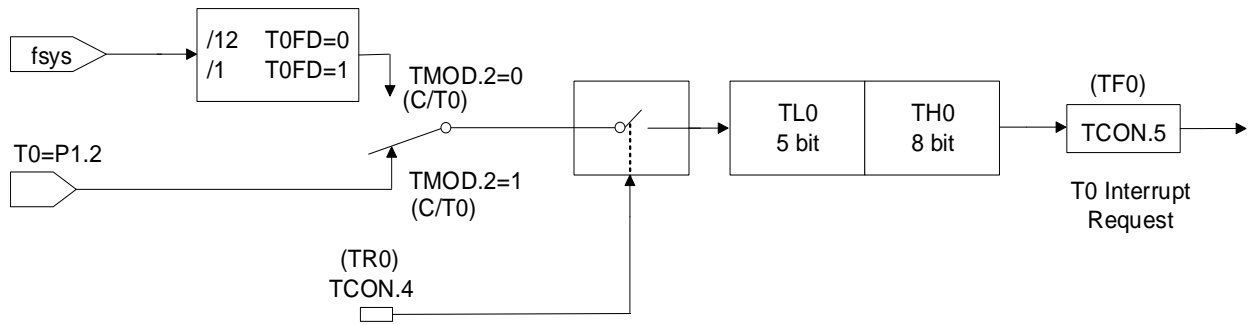

Operating mode 0: 13-bit Timer/Counter

Operating Mode 1: 16 Counter/Timer

Except for using 16 bits of (valid for all 8 bits of TL0) Timer/Counter, in mode 1 and mode 0, the operating mode, opening and configuration method are the same.

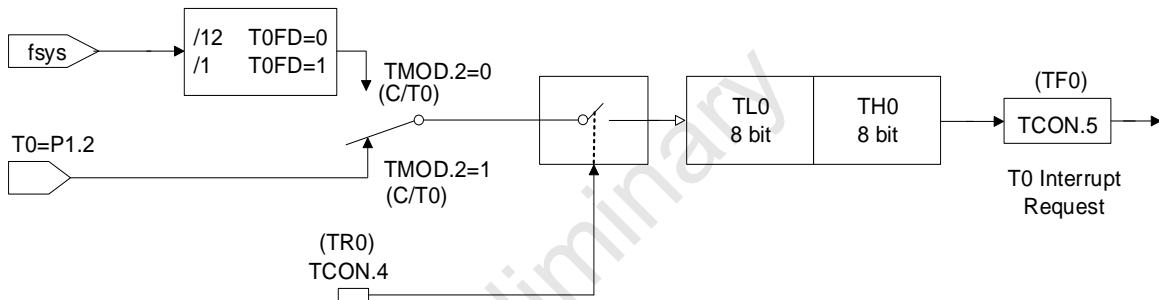

Operating mode 1: 16-bit Timer/Counter

Operating Mode 2: 8 Automatic Reload Counter/Timer

In operating mode 2, Timer0 is 8-bit automatic reload Timer/Counter. TL0 is to store counting value and TH0 is to store the reload value. When the counter in TL0 overflows and turn to 0x00, the overflow flag of Timer TF0 will be set to 1, and the data in register TH0 will be reloaded into register TL0. If the timer interrupt enabled, setting TF0 to 1 will generate an interrupt, but the reloaded value in TH0 will remain the same. Before starting the Timer to count correctly, TL0 shall be initialized to the required value.

Except for automatic reloaded function, the enabling and configuration mode of Timer/Counter in operating mode 2 shall be the same as that in mode 0 and mode 1.

When configured as a timer, the SFR TMCON bit 0 (T0FD) is used to select fractional frequency ratio of system clock f_{sys} .

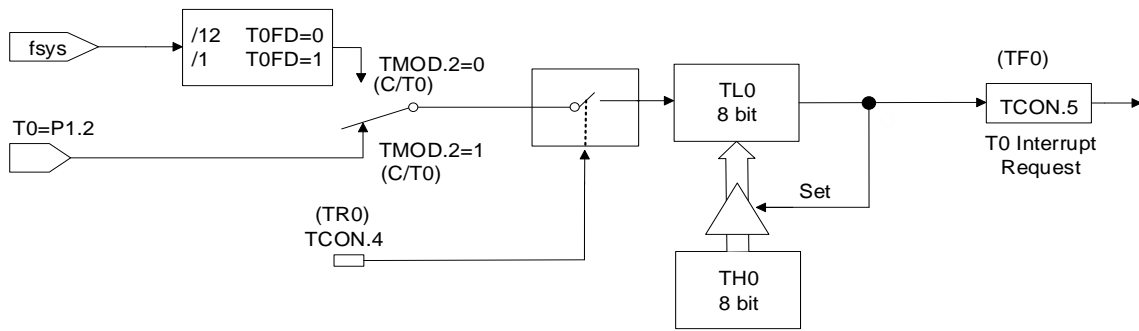

Operating Mode 2: 8 Automatic Reload Counter/Timer

Operating Mode 3: Two 8-bit Counter/Timer (only for Timer0)

In operating mode 3, Timer0 is used as two independent 8-bit Timer/Counters, respectively controlled by TL0 and TH0. TL0 is controlled by control bit (in TCON) and status bit (in TMOD) of Timer0 (TR0), C/T0, TF0. Timer0 is selected as Timer or Counter by TMOD bit 2 (C/T0).

TH0 is only limited to in Timer Mode, which is unable to configure as a Counter by TMOD.2 (C/T0). TH0 is enabled by set the timer control bit TR1 to 1. When overflow occurs and interrupt is discovered, set TF1 to 1 and proceed the interrupt as T1 interrupt.

When T0 is configured in Operating Mode 3, TH0 Timer occupies T1 interrupt resources and TCON register and the 16-bit counter of T1 will stop counting, equivalently "TR1=0". When adopting TH0 timer, it is required to configure TR1=1.

10.3 T1 Operating Mode

Timer1 can be configured in one of three operating modes by setting the bit pairs (M11, M01) in the TMOD register.

Operating mode 0: 13-bit Timer/Counter

TH1 register is to store high 8-bit (TH1.7 ~ TH1.0) of 13-bit Timer/Counter and TL1 is to store low 5-bit (TL1.4 ~ TL1.0). The high 3-bit of TL1 (TL1.7 ~ TL1.5) are uncertain values, they shall be omitted upon reading. When 13-bit Timer/Counter overflow with count increment, the system will set timer overflow flag TF1 as 1. An interrupt will be generated if the timer1 interrupt is enabled. C/T1 bit selects the clock input source of Timer/Counter.

If C/T1=1, the level fluctuation from high to low of timer1 input pin T1 (P1.3) will make timer1 data register add 1. If C/T1=0, the frequency division of system clock is the clock source of timer1.

When TR1 is set to 1 and the timer is enabled. Setting TR1 does not force to reset timer counters, it means; if set TR1 to 1, the timer register will start to count from the value of last clearing of TR1. Therefore, before allowing timer, it is required to configure the initial value of timer register.

When configured as timer, the SFR T1FD is used to select fractional frequency ratio of clock source.

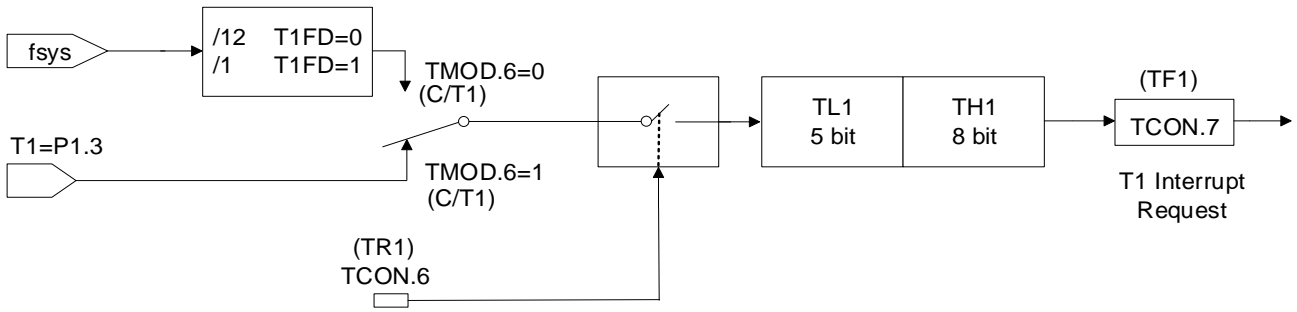

Operating mode 0: 13-bit Timer/Counter

Operating Mode 1: 16 Counter/Timer

Except for using 16-bit (valid for 8-bit data of TL1) Timer/Counter, the operating mode of mode 1 and mode 0 is the same. And the opening and configuration mode of both are also the same.

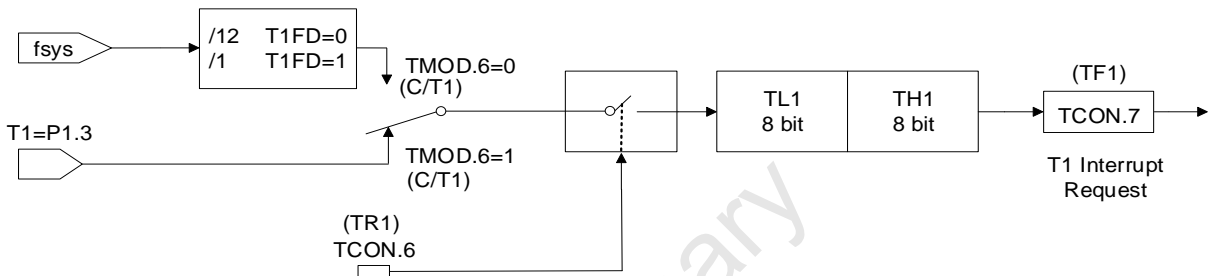

Operating mode 0: 16-bit Timer/Counter

Operating Mode 2: 8 Automatic Reload Counter/Timer

In operating mode 2, Timer1 is 8-bit automatic reload Timer/Counter. TL1 is to store counting value and TH1 is to store the reload value. When the counter in TL1 overflows 0x00, the overflow flag of Timer TF1 will be set to 1, and the value of register TH1 will be reloaded into register TL1. If enable the timer interrupt, setting TF1 to 1 will generate an interrupt, but the reloaded value in TH1 will remain unchanged. Before allowing Timer to correctly count, TL1 shall be initialized to the required value.

Except for automatic reloaded function, the enabling and configuration mode of Timer/Counter in operating mode 2 shall be the same as that of mode 0 and mode 1.

When configured as timer, the SFR TMCON bit 4 (T1FD) is used to select the ratio of clock source of timer to fractional frequency of system clock f_{sys} .

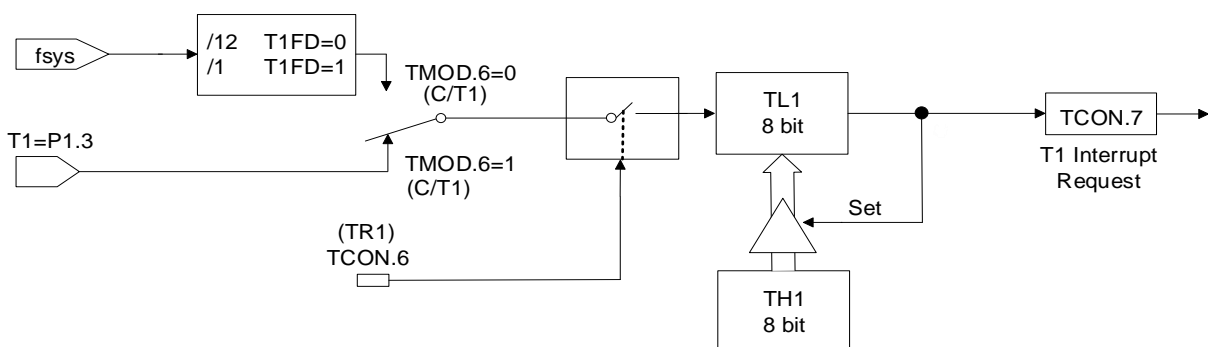

Operating Mode 2: 8 Automatic Reload Counter/Timer

11 TIMER / EVENT COUNTER TIMER2

Timer2 inside the SC92F732X microcontroller unit has two operating modes, namely counter mode and timer mode. There is a control bit C/T2 in SFR T2CON to select Timer or Counter for T2. They are adding counters in nature, differing in counting source. The clock source of T2 comes from system clock or frequency division clock, but the source of counters is the input pulse to external pin. TR2 is the counting switch of Timer/Counter T2. Only when TR2 = 1, will T2 be enabled for counting.

In counter mode, each input pulse on T2 pin will make the counting value of T2 increase by 1.

In timer mode, users can select $f_{sys}/12$ or f_{sys} as counting source of T2 by configuring SFR TMCON.

Timer/Counter T2 has 4 operating modes:

- ① Mode 0: 16-bit capture mode
- ② Mode 1: 16-bit automatic reload timer mode
- ③ Mode 2: Baud rate generator mode
- ④ Mode 3: Programmable clock output mode

11.1 T2-related SFR

Symbol	Address	Description	7	6	5	4	3	2	1	0	Reset Value
T2CON	C8H	Timer2 Control Register	TF2	EXF2	RCLK	TCLK	EXEN2	TR2	C/T2	CP/RL2	0000000b
T2MOD	C9H	Timer2 Operating Mode Register	-	-	-	-	-	-	T2OE	DCEN	xxxxxx00b
RCAP2L	CAH	Timer2 Reload/Capture Low Byte	RCAP2L[7: 0]								0000000b
RCAP2H	CBH	Timer2 Reload/Capture High Byte	RCAP2H[7: 0]								0000000b
TL2	CCH	Timer2 Low Byte	TL2[7: 0]								0000000b
TH2	CDH	Timer2 High Byte	TH2[7: 0]								0000000b
TMCON	8EH	Timer Frequency Control Register	-	-	-	-	-	T2FD	T1FD	T0FD	xxxxx000b

Register instructions are shown below:

T2CON (C8H) Timer2 Control Register (Read/Write)

Bit Number	7	6	5	4	3	2	1	0
Bit Symbol	TF2	EXF2	RCLK	TCLK	EXEN2	TR2	C/T2	CP/RL2
R/W	R/W	R/W	R/W	R/W	R/W	R/W	R/W	R/W
POR	0	0	0	0	0	0	0	0

Bit Number	Bit Symbol	Description
7	TF2	Timer2 overflow flag bit 0: No overflow (must be cleared by software) 1: Overflow (if RCLK=0 and TCLK=0, set to 1 by hardware)
6	EXF2	T2 pin external event input (falling edge) detected flag bit 0: No external event input (must be cleared by software) 1:When detecting external input (if EXEN2=1, SET to 1 by hardware)
5	RCLK	UART receiving clock control bit 0: Timer1 generates receiving baud rate 1: Timer2 generates receiving baud rate
4	TCLK	UART transmitting clock control bit 0: Timer1 generates transmitting baud rate 1: Timer2 generates transmitting baud rate
3	EXEN2	External event input (falling edge) on T2 pin used as reload/capture trigger allowed/prohibited control bit 0: Omit event on T2 pin 1: When the timer2 is not used as UART clock (T2EX always including pull-up resistance), a falling edge is detected on T2 pin and a capture or reload will be generated.

2	TR2	Timer2 start/stop control bit 0: Stop Timer2 1: Start Timer2
1	C/T2	Timer2 Timer/Counter mode selection bit 2 0: Timer mode, used as I/O interface on T2 pin 1: Counter mode
0	CP/RL2	Capture/reload mode selection bit 0: 16-bit Timer/Counter with reload function 1: 16-bit Timer/Counter with capture function, T2EX as timer2 external capture signal input port

T2MOD (C9H) Timer2 Operating Mode Register (Read/Write)

Bit Number	7	6	5	4	3	2	1	0
Bit Symbol	-	-	-	-	-	-	T2OE	DCEN
R/W	-	-	-	-	-	-	R/W	R/W
POR	x	x	x	x	x	x	0	0

Bit Number	Bit Symbol	Description
1	T2OE	Timer2 output allow bit 0: Set T2 as clock input or I/O port 1: Set T2 as clock output
0	DCEN	Decreasing counting allow bit 0: Prohibits Timer2 as incremental/decreasing counter, Timer2 only used as incremental counter 1: Allow Timer2 as incremental/decreasing timer

7 ~ 2	-	Reserved
-------	---	----------

TMCON (8EH) Timer Frequency Control Register (Read/Write)

Bit Number	7	6	5	4	3	2	1	0
Bit Symbol	-	-	-	-	-	T2FD	T1FD	T0FD
R/W	-	-	-	-	-	R/W	R/W	R/W
POR	x	x	x	x	x	0	0	0

Bit Number	Bit Symbol	Description
2	T2FD	T2 input frequency selection control bit 0: T2 clock source is $f_{SYS}/12$ 1: T2 clock source is f_{SYS}

IE (A8H) Interrupt Enable Register (Read/Write)

Bit Number	7	6	5	4	3	2	1	0
Bit Symbol	EA	EADC	ET2	-	ET1	EINT1	ET0	EINT0
R/W	R/W	R/W	R/W	-	R/W	R/W	R/W	R/W
POR	0	0	0	x	0	0	0	0

Bit Number	Bit Symbol	Description
5	ET2	Timer2 interrupt enable control bit 0: Disable TIMER2 interrupt 1: Enable TIMER2 interrupt

IP (B8H) Interrupt Priority Control Register (Read/Write)

Bit Number	7	6	5	4	3	2	1	0
Bit Symbol	-	IPADC	IPT2	-	IPT1	IPINT1	IPT0	IPINT0
R/W	-	R/W	R/W	-	R/W	R/W	R/W	R/W
POR	x	0	0	x	0	0	0	0

Bit Number	Bit Symbol	Description
5	IPT2	Timer2 interrupt priority selection bit 0: Configure Timer2 interrupt priority as “low” 1: Configure Timer2 interrupt priority as “high”

11.2 T2 Operating Mode

The operating mode and configuration mode of Timer2 are shown in the table below:

C/T2	T2OE	DCEN	TR2	CP/RL2	RCLK	TCLK	Mode	
X	0	X	1	1	0	0	0	16-bit capture
X	0	0	1	0	0	0	1	16-bit automatic reload timer
X	0	1	1	0	0	0		
X	0	X	1	X	1	X	2	Baud Rate Generator
					X	1		
0	1	X	1	X	0	0	3	Only used for programmable clock
					1	X	3	Programmable clock output with baud rate generator
					X	1		
X	X	X	0	X	X	X	X	Timer2 stops, but T2EX channel is also available
1	1	X	1	X	X	X		Not recommended

Operating Mode 0: 16-bit capture

In capture mode, there are two options for EXEN2 bit in T2CON.

If EXEN2 = 0, Timer2 is taken as 16-bit timer or counter; if ET2 is set to 1, Timer2 will set up TF2 and generate an interrupt when Timer2 overflows.

If EXEN2=1, conduct the same operations as above on Timer2, the falling edge signal on external input T2EX can make current value in TH2 and TL2 captured into RCAP2H and RCAP2L. Besides, the falling edge signal on T2EX can also cause EXF2 in T2CON to be set to 1. If ET2 is set to 1, bit EXTF2, like TF2, will also trigger an

interrupt.

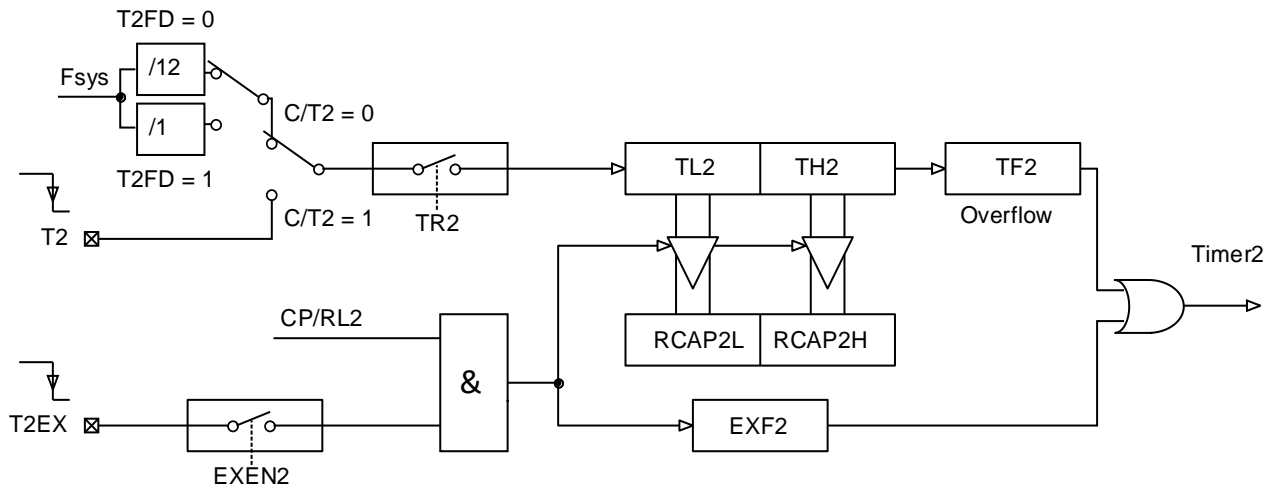

Operating Mode 0: 16-bit capture

Operating Mode 1: 16-bit Automatic Reload Timer

In the 16-bit automatic reload mode, Timer2 can be selected to work in incrementing or decreasing counting mode. This function can be selected by DCEN bit in T2MOD (decreasing counting allowed). After system reset, the reset value of DCEN bit is 0 and Timer2 is defaulted as decreasing counting. When setting DCEN to 1, the incrementing or decreasing counting depends on the level of T2EX pin.

When DCEN = 0, There are two options for EXEN2 bit in T2CON:

1. EXEN=0, Timer2 will increase to 0xFFFFH and set TF2 bit after overflow. Meanwhile, the timer will load 16-bit value in registers RCAP2H and RCAP2L written by user software into registers TH2 and TL2 automatically.
2. EXEN2=1, both the overflow and the falling edge signal on external input T2EX can trigger a 16-bit count value reloading and set EXF2 bit. If T2 interrupt is enabled (ET2=1), both TF2 and EXF2 bit can generate an interrupt.

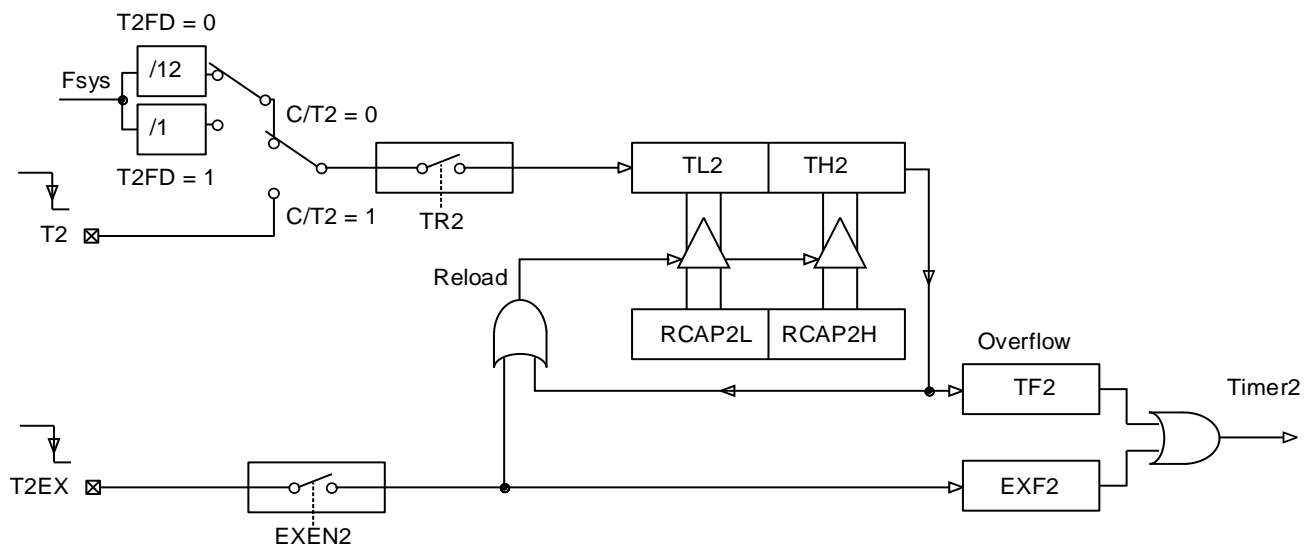

Operating Mode 1: 16-bit Automatic Reload Timer DCEN = 0

Configure DCEN bit to allow Timer2 for incremental or decreasing counting. When DCEN=1, T2EX pin controls the count direction, and the control of EXEN2 becomes invalid.

Setting T2EX to 1 can conduct incremental count on Timer2. The Timer overflows when it increases to 0xFFFFH, then it sets TF2 bit. Besides, the overflow can also respectively cause 16-bit value in RCAP2H and RCAP2L to be reloaded into timer registers.

Setting T2EX to 0 can conduct decreasing count on Timer2. When the value in TH2 and TL2 is equal to that of RCAP2H and RCAP2L, the timer overflows. TF2 bit will be set up and 0xFFFFH reloaded into timer register.

No matter whether timer2 overflows or not, bit EXF2 will be used as the 17th bit of the results. Under such operating mode, EXF2 is no longer taken as interrupt flag.

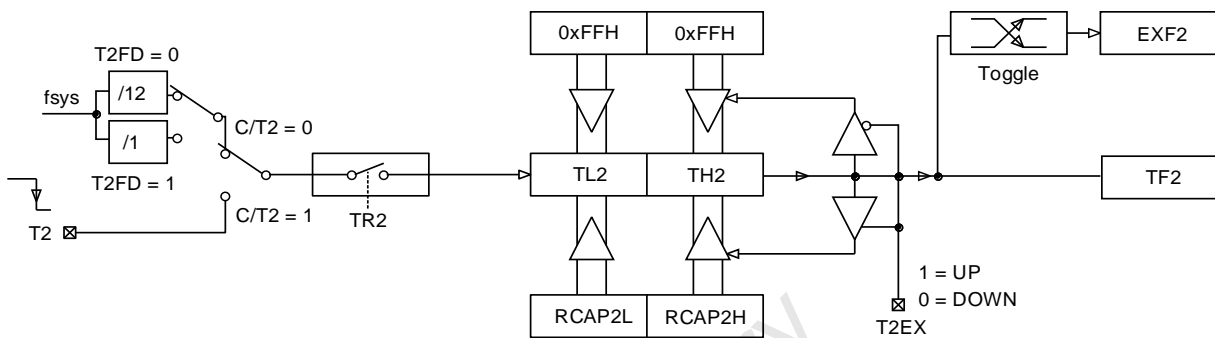

Operating Mode 1: 16-bit Automatic Reload Timer DCEN = 1

Operating Mode 2: Baud Rate Generator

Configure TCLK and RCLK in T2CON register to select Timer2 as baud rate generator. The baud rate of receiver and transmitter can be different. If Timer2 is taken as either one between receiver and transmitter, Timer1 will be taken as another.

Configure TCLK and RCLK in T2CON register to make Timer2 in baud rate generator mode. Such mode is similar to automatic reload mode

Overflow of Timer2 can make the value in registers RCAP2H and RCAP2L reloaded into the Timer2 and counting, but no interrupt will occur.

If EXEN2 is set to 1, the falling edge on T2EX pin will be set up EXF2 without a reloading. Therefore, when Timer2 is taken as baud rate generator, T2EX can be taken as an additional external interrupt

The baud rate of UART mode 1 and mode 3 depends on overflow rate of Timer2 and the following formula:

$$\text{BaudRate} = \frac{1}{16} \times \frac{\text{fn2}}{(65536 - [\text{RCAP2H}, \text{RCAP2L}]) \times 2}$$

Including, fn2 is the clock frequency of Timer2

$$\text{fn2} = \frac{\text{fsys}}{12}; \quad \text{T2FD} = 0$$

$$\text{fn2} = \text{fsys}; \quad \text{T2FD} = 1$$

The schematic diagram of Timer2 as baud rate generator is shown as follows:

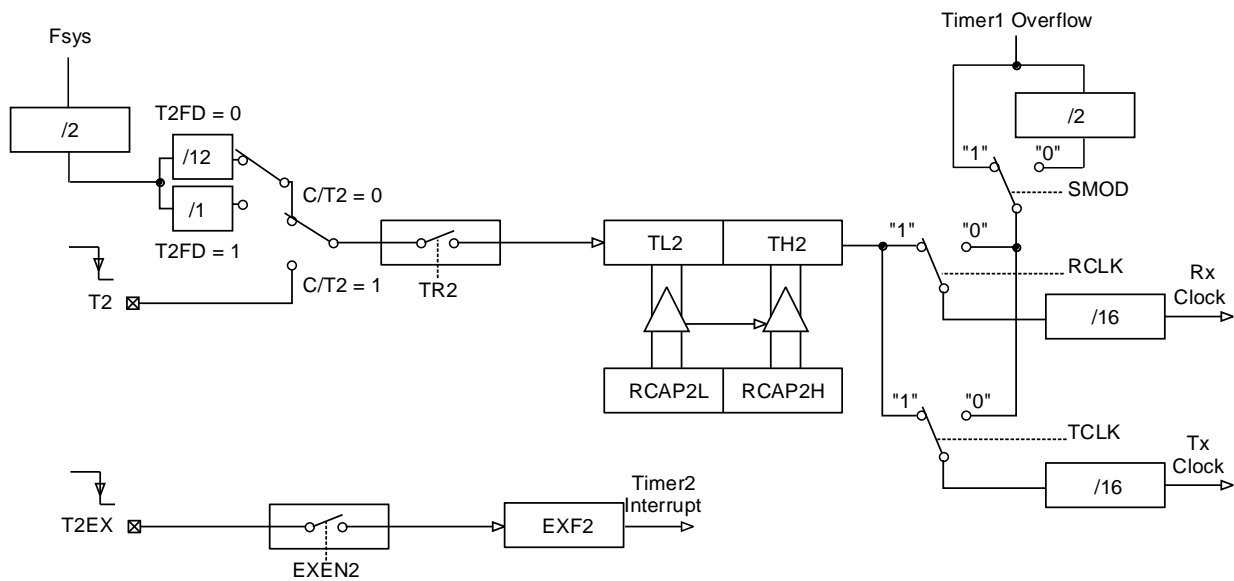

Mode 2: Baud Rate Generator

Operating Mode 3: Programmable Clock Output

In this mode, T2 can be programmed to output a 50% duty cycle clock: when $C/\overline{T2} = 0$ and $T2OE = 1$, Timer2 is taken as clock generator

In this mode, duty cycle of T2 output clock is 50%

$$\text{Clock Out Frequency} = \frac{fn2}{(65536 - [RCAP2H, RCAP2L]) \times 4};$$

Including, $fn2$ is the clock frequency of Timer2

$$fn2 = \frac{f_{sys}}{12}; \quad T2FD = 0$$

$$fn2 = f_{sys}; \quad T2FD = 1$$

Overflow of Timer2 does not generate an interrupt, T2 pin is taken as clock output.

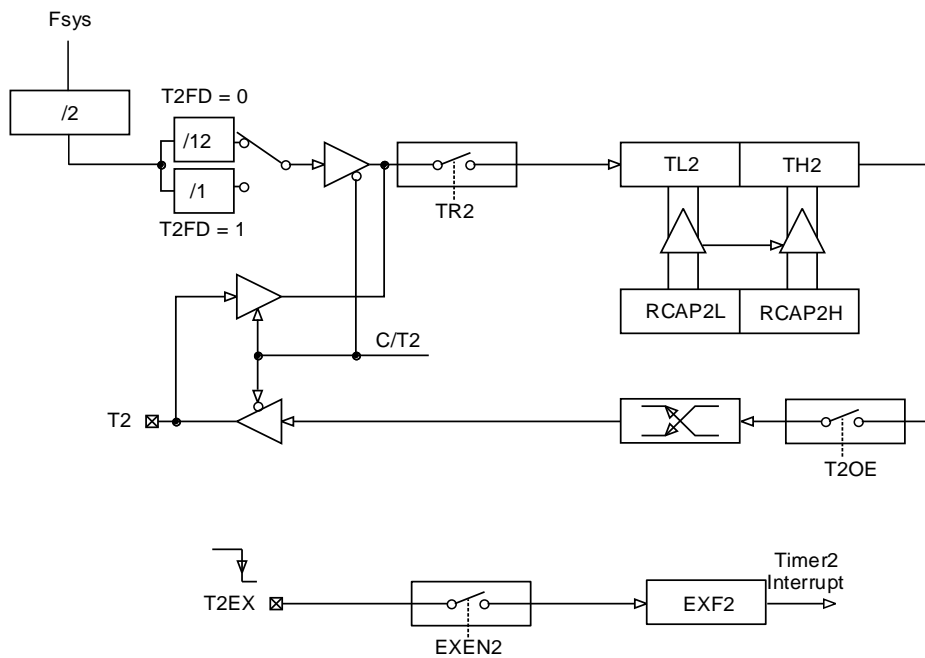

Operating Mode 3: Programmable Clock Output

Note:

1. Both TF2 and EXF2 can generate interrupt request of Timer2, both of which has the same interrupt vector;
2. TF2 and EXF2 can be set by software, only software and hardware reset can clear TF2 and EXF2;
3. When EA = 1 and ET2 = 1, setting up TF2 or EXF2 to 1 can arouse interrupt of Timer2;
4. When Timer2 is taken as baud rate generator, the value written in TH2/TL2 or RCAP2H/RCAP2L may influence the accuracy of baud rate and thus result in error of communication.

12 PWM

The SC92F732X provides an independent counter, which is able to support 3-channel PWM output: PWM0 ~ 2.

The SC92F732X PWM has the following functions:

- ① 8+2-bit precision;
- ② PWM0 ~ 2 shared the same clock cycle, but the duty cycle of each PWM channel can be configured separately
- ③ Output can be configured in forward or reverse direction;
- ④ Provide one PWM overflow interrupt.
- ⑤ The output of PWM0 ~ 2 can be switched to different IO ports

The cycle and duty cycle of the SC92F732X PWM is adjustable. Register PWMCON controls the related setting of PWM0 ~ 2 status and PWMCFG sets the common cycle of PWM, and PWMDTY0 , PWMDTY 1 and PWMDTY 2 respectively control the duty ratio of PWM0 ~ 2. PWMDTYA controls the fine tuning of three PWM output duty.

12.1 PWM block Diagram

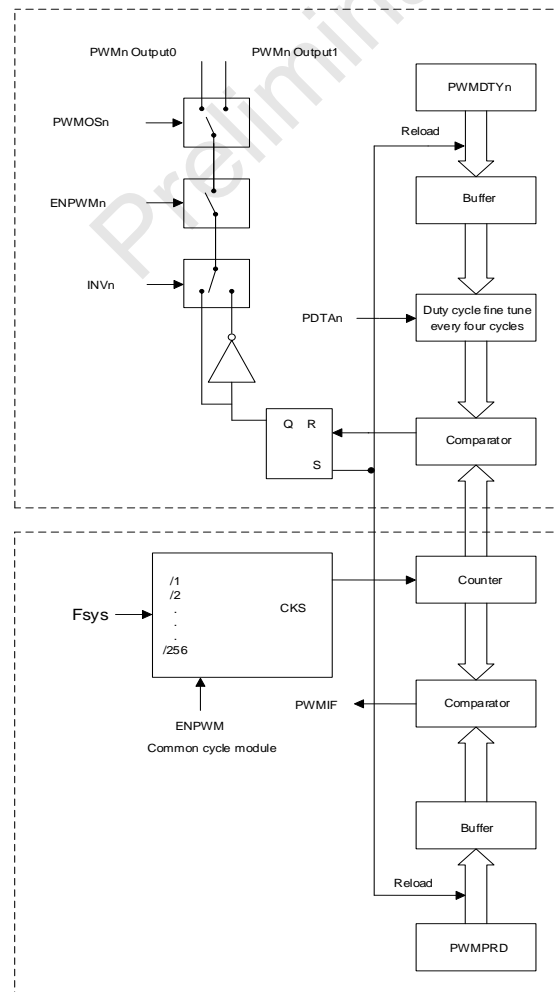

The SC92F732X PWM block Diagram

12.2 PWM-related SFR Registers

Symbol	Address	Description	7	6	5	4	3	2	1	0	Reset Value
PWMCFG	D1H	PWM Configuration Register	-		INV2	INV1	INV0	PWMOS ₂	PWMOS ₁	PWMOS ₀	xx000000b
PWMCON	D2H	PWM Control Register	ENPWM	PWMIF	ENPWM2	ENPWM1	ENPWM ₀	PWMCK _{S2}	PWMCK _{S1}	PWMCK ₀	00000000b
PWMPRD	D3H	PWM Period Setting Register	PWMPRD[7: 0]								00000000b
PWMDTY _A	D4H	PWM Duty Cycle Configuration Register A	-		PDT2[1: 0]		PDT1[1: 0]		PDT0[1: 0]		xx000000b
PWMDTY0	D5H	PWM0 Duty Cycle Configuration Register	PDT0[7: 0]								00000000b
PWMDTY1	D6H	PWM1 Duty Cycle Configuration Register	PDT1[7: 0]								00000000b
PWMDTY2	D7H	PWM2 Duty Cycle Configuration Register	PDT2[7: 0]								00000000b
IE1	A9H	Interrupt Enable register 1	-	-	-	-	EINT2	EBTM	EPWM	-	xxx000xb
IP1	B9H	Interrupt Priority Control Register 1	-	-	-	-	IPINT2	IPBTM	IPPWM	-	xxx000xb

PWMCON (D2H) PWM Control Register (Read/Write)

Bit Number	7	6	5	4	3	2	1	0
Bit Symbol	ENPWM	PWMIF	ENPWM2	ENPWM1	ENPWM0	PWMCKS[2:0]		
R/W	R/W	R/W	R/W	R/W	R/W	R/W		

POR	0	0	0	0	0	0	0	0
-----	---	---	---	---	---	---	---	---

Bit Number	Bit Symbol	Description
7	ENPWM	<p>PWM module switch control bit (Enable PWM)</p> <p>1: Enable Clock to enter PWM unit and PWM starts to work</p> <p>0: PWM unit stops operating and PWM counter resets to zero. PWMn still connects to output pin. If using other functions multiplexed with PWMn output pin, set ENPWMn to 0</p>
6	PWMIF	<p>PWM interrupt flag</p> <p>When PWM counter overflows (that is to say, the figure exceeds PWMPRD), this bit will be automatically set to 1 by hardware. If at this time IE1[1] (EPWM) is set to 1 as well, PWM interrupt generates.</p> <p>The hardware would not automatically clear this bit after the PWM interrupt generates, which must be cleared by the user's software.</p>
5	ENPWM2	<p>PWM2 functional switch control bit</p> <p>0: PWM2 do not output to IO</p> <p>1: PWM2 output to IO</p>
4	ENPWM1	<p>PWM1 functional switch control bit</p> <p>0: PWM1 do not output to IO</p> <p>1: PWM1 output to IO</p>
3	ENPWM0	<p>PWM0 functional switch control bit</p> <p>0: PWM0 do not output to IO</p> <p>1: PWM0 output to IO</p>
2~0	PWMCKS[2:0]	<p>PWM Clock Source Selector</p> <p>000: f_{SYS}</p> <p>001: $f_{SYS}/2$</p> <p>010: $f_{SYS}/4$</p> <p>011: $f_{SYS}/8$</p> <p>100: $f_{SYS}/32$</p> <p>101: $f_{SYS}/64$</p> <p>110: $f_{SYS}/128$</p>

		111: $f_{sys}/25$
--	--	-------------------

PWMPRD[7:0] is a sharing cycle setting controller for three-channel PWM. Once the PWM counter counting to the preset value of PWMPRD[7:0], the counter will hop to 00h when the next PWM CLK comes, that is to say, the cycle of $pwm0/1/2$ is $(PWMPRD[7:0] + 1) * PWM$ clock.

The counting time of PWM counter can be controlled by PWMCKS[2:0]. Different number of system clocks can be selected to count one unit (pre-scalar selector), that is select the divider ratio of PWM counter clock source to system clock f_{sys} . PWM0/1/2 can also be used by PWMCFG INV0~INV2 to select whether or not the PWM output is reversed.

PWMPRD (D3H) PWM Period Configuration Register (Read/Write)

Bit Number	7	6	5	4	3	2	1	0
Bit Symbol	PWMPRD[9: 2]							
R/W	R/W	R/W	R/W	R/W	R/W	R/W	R/W	R/W
POR	0	0	0	0	0	0	0	0

Bit Number	Bit Symbol	Description
7~0	PWMPRD[7:0]	The Sharing Cycle Settings Of PWM0 ~ 2; This value represents the (period - 1) of the output waveform of PWM0, PWM1 and PWM2; That is to say, the period value of PWM output is $(PWMPRD[7:0] + 1) * PWM$ clock;

PWMCFG (D1H) PWM Configuration Register (Read/Write)

Bit Number	7	6	5	4	3	2	1	0
Bit Symbol	-	-	INV2	INV1	INV0	PWMOS2	PWMOS1	PWMOS0
R/W	R/W	R/W	R/W	R/W	R/W	R/W	R/W	R/W
POR	0	0	0	0	0	0	0	0

Bit Number	Bit Symbol	Description
------------	------------	-------------

5	INV2	PWM2 output reverse control bit 0: PWM2 output not invert 1: PWM2 output reverse
4	INV1	PWM1 output reverse control bit 0: PWM1 output not invert 1: PWM1 output reverse
3	INV0	PWM0 output reverse control bit 0: PWM0 output not invert 1: PWM0 output reverse
2	PWMOS2	PWM2 output pin selection 0: PWM2 output for P0.2 1: PWM2 output for P2.7
1	PWMOS1	PWM1 output pin selection 0: PWM1 output for P0.1 1: PWM1 output for P2.6
0	PWMOS0	PWM0 output pin selection 0: PWM0 output for P0.0 1: PWM0 output for P2.5
7~6	-	Reserve

PWM0DTY0 (D5H) PWM0 Duty Cycle Configuration Register (Read/Write)

Bit Number	7	6	5	4	3	2	1	0
Bit Symbol	PDT0[7: 0]							
R/W	R/W	R/W	R/W	R/W	R/W	R/W	R/W	R/W
POR	0	0	0	0	0	0	0	0

Bit Number	Bit Symbol	Description
7 ~ 0	PDT0[7: 0]	PWM0 duty cycle length configuration; High level width of PWM0 is (PDT0[7: 0]) PWM clocks.

PWMDTY1 (D6H) PWM1 Duty Cycle Configuration Register (Read/Write)

Bit Number	7	6	5	4	3	2	1	0
Bit Symbol	PDT1[7: 0]							
R/W	R/W	R/W	R/W	R/W	R/W	R/W	R/W	R/W
POR	0	0	0	0	0	0	0	0

Bit Number	Bit Symbol	Description
7 ~ 0	PDT1[7: 0]	PWM1 duty cycle length configuration; High level width of PWM1 is (PDT1[7: 0]) PWM clocks.

PWMDTY2 (D7H) PWM2 Duty Cycle Configuration Register (Read/Write)

Bit Number	7	6	5	4	3	2	1	0
Bit Symbol	PDT2[7: 0]							
R/W	R/W	R/W	R/W	R/W	R/W	R/W	R/W	R/W
POR	0	0	0	0	0	0	0	0

Bit Number	Bit Symbol	Description
7 ~ 0	PDT2[7: 0]	PWM2 duty cycle length configuration;

		High level width of PWM2 is (PDT2[7: 0]) PWM clocks.
--	--	--

PWMDTYA (D4H) PWM Duty Cycle Configuration Register (Read/Write)

Bit Number	7	6	5	4	3	2	1	0
Bit Symbol	-		PDTA2[1: 0]		PDTA1[1: 0]		PDTA0[1: 0]	
R/W	-	-	R/W	R/W	R/W	R/W	R/W	R/W
POR	x	x	0	0	0	0	0	0

Bit Number	Bit Symbol	Description
5~ 4	PDTA2[1:0]	PWM2 duty fine-tuning control, with per cycle of four PWM2 cycles 00: The output duty of the four PWM2 is PDT2 set value;(D, D, D, D) 01: The output duty from the first PWM2 is PDT2 set value plus 1, and the duty output from the other three PWM2 is PDT2 set value;(D+1, D, D, D) 10: The output duty of the first and second PWM2 is PDT2 set value plus 1, and the duty output of the other two PWM2 is PDT2 set value;(D+1, D+1, D, D) 11 : The first, second and third PWM2 output duty is PDT2 set value plus 1, and the fourth PWM2 output duty is PDT2 set value.(D+1, D+1, D+1, D)
3~2	PDTA1[1:0]	PWM1 duty fine-tuning control, with per cycle of four PWM1 cycles 00: The output duty of the four PWM1 is PDT1 set value;(D, D, D, D) 01: The output duty from the first PWM1 is PDT1 set value plus 1, and the duty output from the other three PWM1 is PDT1 set value;(D+1, D, D, D) 10: The output duty of the first and second PWM1 is PDT1 set value plus 1, and the duty output of the other two PWM1 is PDT1 set value;(D+1, D+1, D, D) 11 : The first, second and third PWM1 output duty is PDT1 set value plus 1, and the fourth PWM1 output duty is PDT1 set value.(D+1, D+1, D+1, D)

1~0	PDTA0[1:0]	<p>PWM0 duty fine-tuning control, with per cycle of four PWM0 cycles</p> <p>00: The output duty of the four PWM0 is PDT0 set value;(D, D, D, D)</p> <p>01: The output duty from the first PWM0 is PDT0 set value plus 1, and the duty output from the other three PWM0 is PDT0 set value;(D+1, D, D, D)</p> <p>10: The output duty of the first and second PWM0 is PDT0 set value plus 1, and the duty output of the other two PWM0 is PDT0 set value;(D+1, D+1, D, D)</p> <p>11 : The first, second and third PWM0 output duty is PDT0 set value plus 1, and the fourth PWM0 output duty is PDT0 set value.(D+1, D+1, D+1, D)</p>
7~6	-	Reserve

IE1 (A9H) Interrupt Enable Register (Read/Write)

Bit Number	7	6	5	4	3	2	1	0
Bit Symbol	-	-	-	-	EINT2	EBTM	EPWM	-
R/W	-	-	-	-	R/W	R/W	R/W	-
POR	x	x	x	x	0	0	0	x

Bit Number	Bit Symbol	Description
1	EPWM	<p>PWM Interrupt Control Bit</p> <p>0: Clear to disable the PWM interrupt</p> <p>1: Set to enable the interrupt when PWM counter overflows</p>

IP1 (B9H) Interrupt Priority Register 1 (Read/Write)

Bit Number	7	6	5	4	3	2	1	0
Bit Symbol	-	-	-	-	IPINT2	IPBTM	IPPWM	-

R/W	-	-	-	-	R/W	R/W	R/W	-
POR	x	x	x	x	0	0	0	x

Bit Number	Bit Symbol	Description
1	IPPWM	PWM interrupt priority selection bit 0: Clear to configure PWM interrupt priority as “low” 1: Set to configure PWM interrupt priority as “ high”

Notes:

1. ENPWM bit can control whether PWM module works or not.
2. ENPWMn bit can select PWMn port as GPIO or PWMn output.
3. EPWM(IE1.1) bit can control whether or not PWM is allowed to generate interrupts.
4. If ENPWM sets as 1, the PWM module is turn on and ENPWMn=0, the PWM output is closed and acts as GPIO. At this time, PWM module can be used as an 8-bit Timer and EPWM(IE1.1) is set as 1 and PWM still produces interrupt.
5. Three PWM sharing cycles, and the PWM interrupt generated when overflow is the same interrupt vector.

12.3 PWM Waveform and Directions

The influence of changing various SFR parameters on PWM waveform is shown as follows:

① Diagram for Duty Cycle Change features

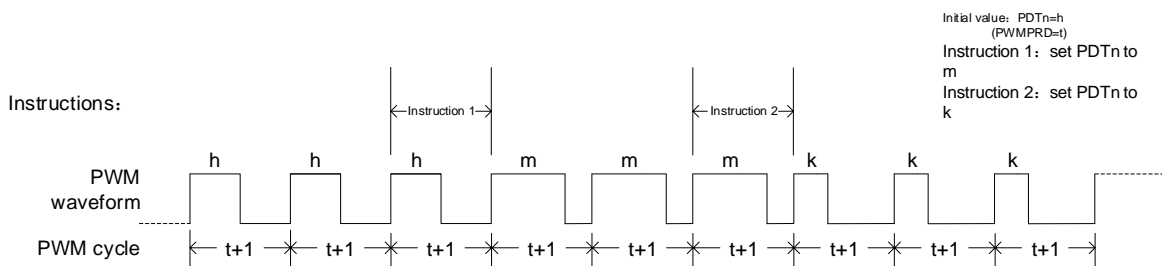

Diagram for Duty Cycle Change Features

When PWMn outputs waveform, if it is required to change the duty cycle, users can change the value of high level configuration registers (PWMDTYn). But note that changing the value of PWMDTYn will not change the duty cycle immediately. It is required to wait until the end of this period and change in the next period. Related waveform output is shown in the figure above.

② Period Change features

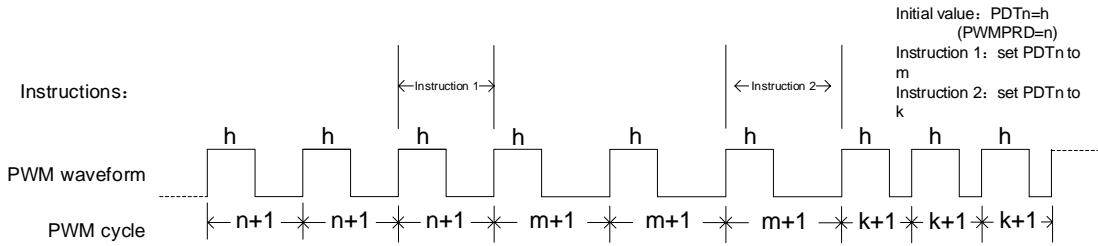

Diagram for Period Change Features

When PWMn outputs waveform, if it is required to change the period, the user can change the value of period configuration registers PWMPRD. Same as changing the duty cycle, change the value of PWMPRD will not change the period immediately. It is required to wait until the end of this period and change in the next period. Refer to the figure above.

③ Relationship between Period and Duty cycle

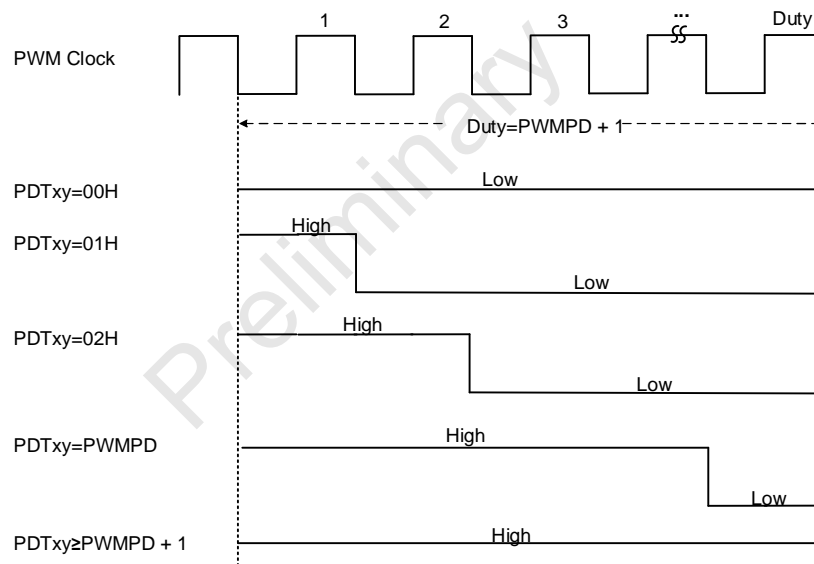
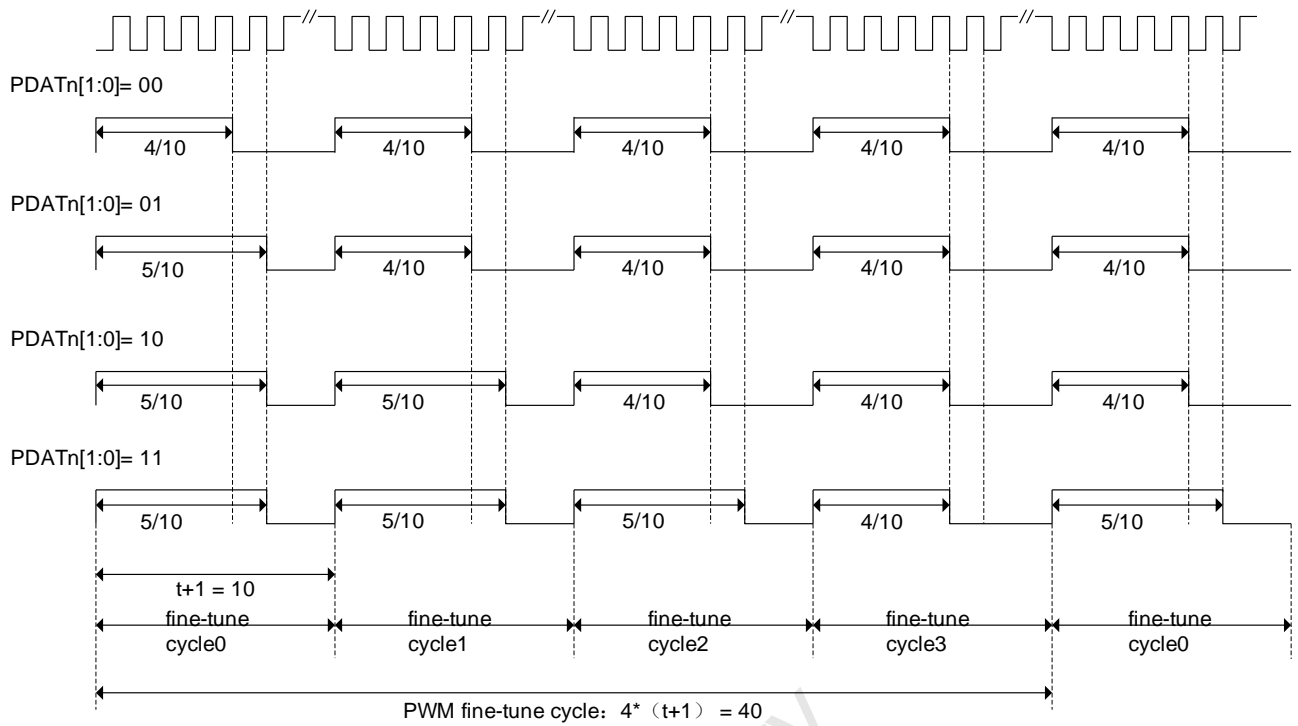

Diagram for Relationship between Period and Duty cycle

The relationship between period and duty cycle is shown in the figure above. The precondition of this result is the PWMn(n=0, 1) output reverse control (INVn) is initialized to 0; if it is required to get the contrary result, set PWMCFG.5(INV2), PWMCFG.4(INV1) and PWMCFG.3(INV0) to 1.

④ 8+2 bit PWM fine-tuning control

The fine-tuning of 3-channel PWM output duty can be control by configured PWMDTYA, with four PWM cycles as one cycle.



8-bit PWM fine-tuning control Diagram

13 GP I/O

The SC92F732X offers up to 26 bidirectional controllable GPIOs, input and output control registers are used to control the input and output state of various ports, when the port is used as input, each I/O port is equipped with internal pull-up resistor controlled by P_xPH_y. Such 26 IOs are shared with other functions, including P0.0 ~ P0.4 can be used as LCD COM driver by configuring output voltage as 1/2 V_{DD}. Under output state, what I/O port read from the value of port data register is the actual state value of the port.

Note: Unused IO port or IO port with no package pin shall be configured as strong push-pull output mode.

13.1 GPIO Structure Diagram

Strong Push-pull Output Mode

In strong push-pull output mode, it is able to provide continuous high current drive: high output for the current larger than 20mA and low output for the current larger than 70mA

The port structure diagram for strong push-pull output mode is shown below:

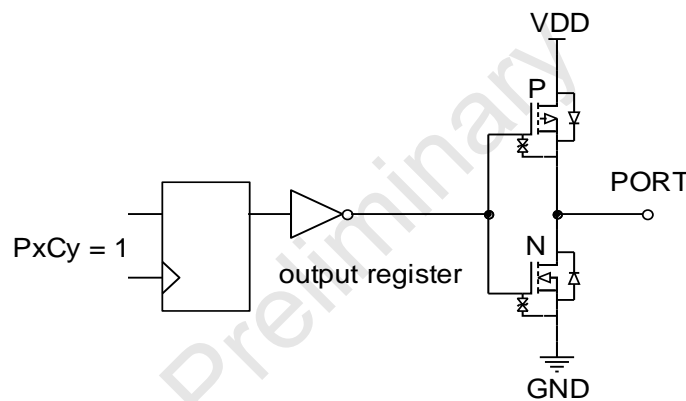

Strong Push-pull Output Mode

Pull-up Input Mode

In pull-up input mode, a pull-up resistor is connected on the input port, only when the level on the input port is pulled down, low level signal can be detected.

The port structure diagram for pull-up input mode is shown below:

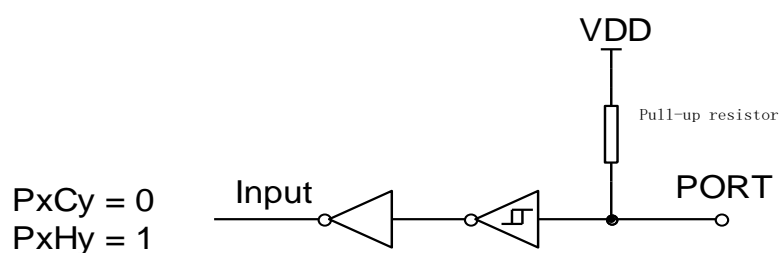

Pull-up Input Mode

High Impedance Input Mode. (Input only)

The port structure diagram for input only mode is shown below:

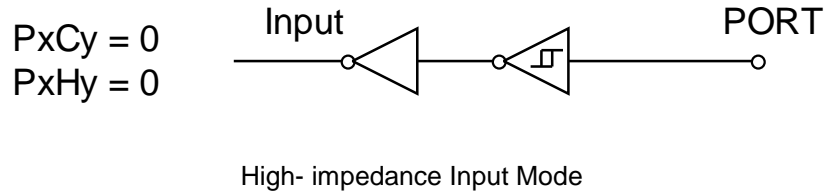

13.2 I/O Port-related Registers

P0CON (9AH) P0 Input / Output Control Register (Read/Write)

Bit Number	7	6	5	4	3	2	1	0
Bit Symbol	P0C7	P0C6	P0C5	P0C4	P0C3	P0C2	P0C1	P0C0
R/W	R/W	R/W	R/W	R/W	R/W	R/W	R/W	R/W
POR	0	0	0	0	0	0	0	0

P0PH (9BH) P0 Pull-up Resistor Control Register (Read/Write)

Bit Number	7	6	5	4	3	2	1	0
Bit Symbol	P0H7	P0H6	P0H5	P0H4	P0H3	P0H2	P0H1	P0H0
R/W	R/W	R/W	R/W	R/W	R/W	R/W	R/W	R/W
POR	0	0	0	0	0	0	0	0

P1CON (91H) P1 Input / Output Control Register (Read/Write)

Bit Number	7	6	5	4	3	2	1	0
Bit Symbol	P1C7	P1C6	P1C5	P1C4	P1C3	P1C2	P1C1	P1C0
R/W	R/W	R/W	R/W	R/W	R/W	R/W	R/W	R/W

POR	0	0	0	0	0	0	0	0
-----	---	---	---	---	---	---	---	---

P1PH (92H) P1 Pull-up Resistor Control Register (Read/Write)

Bit Number	7	6	5	4	3	2	1	0
Bit Symbol	P1H7	P1H6	P1H5	P1H4	P1H3	P1H2	P1H1	P1H0
R/W	R/W	R/W	R/W	R/W	R/W	R/W	R/W	R/W
POR	0	0	0	0	0	0	0	0

P2CON (A1H) P2 Input / Output Control Register (Read/Write)

Bit Number	7	6	5	4	3	2	1	0
Bit Symbol	P2C7	P2C6	P2C5	P2C4	P2C3	P2C2	P2C1	P2C0
R/W	R/W	R/W	R/W	R/W	R/W	R/W	R/W	R/W
POR	0	0	0	0	0	0	0	0

P2PH (A2H) P2 Pull-up Resistor Control Register (Read/Write)

Bit Number	7	6	5	4	3	2	1	0
Bit Symbol	P2H7	P2H6	P2H5	P2H4	P2H3	P2H2	P2H1	P2H0
R/W	R/W	R/W	R/W	R/W	R/W	R/W	R/W	R/W
POR	0	0	0	0	0	0	0	0

P5CON (D9H) P5 Input / Output Control Register (Read/Write)

Bit Number	7	6	5	4	3	2	1	0
Bit Symbol	-	-	-	-	-	-	P5C1	P5C0

R/W	-	-	-	-	-	-	R/W	R/W
POR	x	x	x	x	x	x	0	0

P5PH (DAH) P5 Pull-up Resistor Control Register (Read/Write)

Bit Number	7	6	5	4	3	2	1	0
Bit Symbol	-	-	-	-	-	-	P5H1	P5H0
R/W	-	-	-	-	-	-	R/W	R/W
POR	x	x	x	x	x	x	0	0

Bit Number	Bit Symbol	Description
7 ~ 0	PxCy (x=0 ~ 2, 5, y=0 ~ 7)	Px port input and output control bit 0: Pxy as input mode (initial value) 1: Pxy as strong push-pull output mode
7 ~ 0	PxHy (x=0 ~ 2, 5, y=0 ~ 7)	Px port pull-up resistance configuration, only valid when PxCy=0: 0: Pxy as high-impedance input mode (initial value), the pull-up resistor is turned off. 1: Pxy pull-up resistance is turned on.

P0 (80H) P0 Data Register (Read/Write)

Bit Number	7	6	5	4	3	2	1	0
Bit Symbol	P0.7	P0.6	P0.5	P0.4	P0.3	P0.2	P0.1	P0.0
R/W	R/W	R/W	R/W	R/W	R/W	R/W	R/W	R/W
POR	0	0	0	0	0	0	0	0

P1 (90H) P1 Data Register (Read/Write)

Bit Number	7	6	5	4	3	2	1	0
Bit Symbol	P1.7	P1.6	P1.5	P1.4	P1.3	P1.2	P1.1	P1.0
R/W	R/W	R/W	R/W	R/W	R/W	R/W	R/W	R/W
POR	0	0	0	0	0	0	0	0

P2 (A0H) P2 Data Register (Read/Write)

Bit Number	7	6	5	4	3	2	1	0
Bit Symbol	P2.7	P2.6	P2.5	P2.4	P2.3	P2.2	P2.1	P2.0
R/W	R/W	R/W	R/W	R/W	R/W	R/W	R/W	R/W
POR	0	0	0	0	0	0	0	0

P5 (D8H) P5 Data Register (Read/Write)

Bit Number	7	6	5	4	3	2	1	0
Bit Symbol	-	-	-	-	-	-	P5.1	P5.0
R/W	-	-	-	-	-	-	R/W	R/W
POR	x	x	x	x	x	x	0	0

IOHCON (97H) IOH Configuration Register (Read/Write)

Bit Number	7	6	5	4	3	2	1	0
Bit Symbol	P2H[1: 0]		P2L[1: 0]		P0H[1: 0]		P0L[1: 0]	
R/W	R/W	R/W	R/W	R/W	R/W	R/W	R/W	R/W
POR	0	0	0	0	0	0	0	0

Bit Number	Bit Symbol	Description
7 ~ 6	P2H[1: 0]	P2 high 4-bit IOH configuration bits 00: Set P2 high 4-bit IOH level 0 (Maximum value); 01: Set P2 high 4-bit IOH level 1; 10: Set P2 high 4-bit IOH level 2; 11: Set P2 high 4-bit IOH level 3 (Minimum value);
5 ~ 4	P2L[1: 0]	P2 low 4-bit IOH configuration bits 00: Set P2 low 4-bit IOH level 0 (Maximum value); 01: Set P2 low 4-bit IOH level 1; 10: Set P2 low 4-bit IOH level 2; 11: Set P2 low 4-bit IOH level 3 (Minimum value);
3 ~ 2	P0H[1: 0]	P0 high 4-bit IOH configuration bits 00: Set P0 high 4-bit IOH level 0 (Maximum value); 01: Set P0 high 4-bit IOH level 1; 10: Set P0 high 4-bit IOH level 2; 11: Set P0 high 4-bit IOH level 3 (Minimum value);
1 ~ 0	P0L[1: 0]	P0 low 4-bit IOH configuration bits 00: Set P0 low 4-bit IOH level 0 (Maximum value); 01: Set P0 low 4-bit IOH level 1; 10: Set P0 low 4-bit IOH level 2; 11: Set P0 low 4-bit IOH level 3 (Minimum value);

14 SOFTWARE LCD DRIVER

The P0.0 ~ P0.4 of the SC92F732X can be used as the COM port of the software LCD. In addition to the normal IO functions, these IOs can also output 1/2VDD. The user can select the corresponding IO as the LCD driver COM according to the usage.

14.1 Software LCD Drives Relevant Registers

LCD Driver Related SFR Register Description:

P0VO (9CH) P0 port LCD voltage output register (Read/Write)

Bit Number	7	6	5	4	3	2	1	0
Bit Symbol	-	-	-	P04VO	P03VO	P02VO	P01VO	P00VO
R/W	-	-	-	R/W	R/W	R/W	R/W	R/W
POR	x	x	x	0	0	0	0	0

P0yVO (y=0 ~ 4)	P0y	P0y selection output port
0	x	Ordinary IO port
1	1	Open the LCD voltage output function of Pxy port. The output voltage of Pxy is 1/2V _{DD} .

OTCON (8FH) Output Control Register (Read/Write)

Bit Number	7	6	5	4	3	2	1	0
Bit Symbol			-	-	VOIRS[1: 0]		-	-
R/W	-	-	-	-	R/W	R/W	-	-
POR	x	x	x	x	0	0	x	x

Bit Number	Bit Symbol	Description
3 ~ 2	VOIRS[1: 0]	<p>Selection bits of voltage dividing resistance of LCD voltage output port (suitable driving according to LCD screen size)</p> <p>00: Disable internal voltage divider resistor. (Energy saving)</p> <p>01: Set the internal partial resistance to 12.5K</p> <p>10: Set the internal partial resistance to 37.5K</p> <p>11: Set the internal partial resistance to 87.5K</p>

15 UART

15.1 UART Related Register (Read/Write)

SCON (98H) Serial Port Control Register (Read/Write)

Bit Number	7	6	5	4	3	2	1	0
Bit Symbol	SM0	SM1	SM2	REN	TB8	RB8	TI	RI
R/W	R/W	R/W	R/W	R/W	R/W	R/W	R/W	R/W
POR	0	0	0	0	0	0	0	0

Bit Number	Bit Symbol	Description
7 ~ 6	SM0 ~ 1	<p>Serial communication mode control bits</p> <p>00: Mode 0, 8-bit half-duplex synchronous communication mode. Serial data is received and transmitted on RX pin. TX pin is used to transmit shift clock. Receive and transmit 8 bits for each frame, and low bits will be received or transmitted firstly;</p> <p>01: Mode 1, 10-bit full-duplex asynchronous communication composing of 1 starting bit, 8 data bits and 1 stopping bit, with communication baud rate changeable;</p> <p>10: Mode 2, 11-bit full-duplex asynchronous communication, composing of 1 starting bit, 8 data bits and 1 programmable 9th bit and 1 stopping bit.</p> <p>11: Mode 3, 11-bit full-duplex asynchronous communication, composing of 1 starting bit, 8 data bits and 1 programmable 9th bit and 1 stopping</p>

		bit, with communication baud rate changeable.
5	SM2	Serial communication mode control bit 2, this control bit is only valid for mode 2 and 3 0: RI is set upon receiving a complete data frame to generate interrupt request; 1: When receiving a complete data frame, only when RB8=1, will RI be set to generate interrupt request.
4	REN	Receive allowing control bit 0: Receiving data not allowed; 1: Receiving data allowed.
3	TB8	Only valid for mode 2 and 3, 9 th bit of receiving data
2	RB8	Only valid for mode 2 and 3, 9 th bit of receiving data
1	TI	Transmission interrupt flag bit
0	RI	Reception interrupt flag bit

SBUF (99H) Serial Data Cache Register (Read/Write)

Bit Number	7	6	5	4	3	2	1	0
Bit Symbol	SBUF[7: 0]							
R/W	R/W	R/W	R/W	R/W	R/W	R/W	R/W	R/W
POR	0	0	0	0	0	0	0	0

Bit Number	Bit Symbol	Description
7 ~ 0	SBUF[7: 0]	Serial Port Data Cache Register SBUF contains two registers: one for transmitting shift register and one for receiving latch; data written into SBUF will be transmitted to shift register and initiate transmitting process; reading SBUF will return the contents of receiving latch.

PCON (87H) Power Management Control Register (only readable, * unreadable*)

Bit Number	7	6	5	4	3	2	1	0
Bit Symbol	SMOD	-	-	-	-	-	STOP	IDL
R/W	W	-	-	-	-	-	W	W
POR	0	x	x	x	x	x	0	0

Bit Number	Bit Symbol	Description
7	SMOD	<p>Baud rate multiplying power configuration bit</p> <p>0: When SM0~1 = 00, the serial port operates under clock of 1/12 system clock, and when SM0~1 = 10, the serial port operates under clock of 1/64 system clock.</p> <p>1: When SM0~1 = 00, the serial port operates under clock of 1/4 system clock, and when SM0~1 = 10, the serial port operates under clock of 1/32 system clock.</p>

15.2 Baud Rate of Serial Communication

In mode 0, baud rate can be programmed as 1/12 or 1/4 of system clock and determined by SMOD (PCON.7) bit. When SMOD is clear to 0, the serial port operates in 1/12 of system clock. When SMOD is set to 1, serial port operates in 1/4 of system clock.

In mode 1 and mode 3, the user can select overflow rate of Timer1 or Timer2 as baud rate by configuration.

Set TCLK (T2CON.4) and RCLK (T2CON.5) bit to configure Timer2 as TX and RX clock source of baud rate (Refer to the timer section for details). No matter TCLK or RCLK is set to logic 1, Timer2 can be in the mode of baud rate generator. If TCLK and RCLK are set to logic 0, Timer1 can be baud clock source of Tx and Rx.

Mode 1 and Mode 3 baud rate formula is shown below, including that TH1 are the 8-bit automatic overload register of Timer1, SMOD is UART's baud rate doubler, and [RCAP2H, RCAP2L] are the 16-bit reload registers of Timer2.

1. When Timer1 is used as baud rate generator, Timer1 work at model 2:

$$\text{BaudRate} = \frac{2^{\text{SMOD}}}{16} \times \frac{\text{fn1}}{(256-\text{TH1}) \times 2}$$

Including, fn1 is the clock frequency of Timer1:

$$\text{fn1} = \frac{\text{fsys}}{12}; \quad \text{T1FD} = 0$$

$$\text{fn1} = \text{fsys}; \quad \text{T1FD} = 1$$

2. When Timer2 is used as baud rate generator:

$$\text{BaudRate} = \frac{1}{16} \times \frac{fn2}{(65536 - [\text{RCAP2H}, \text{RCAP2L}]) \times 2}$$

Including, fn2 is the clock frequency of Timer2:

$$fn2 = \frac{fsys}{12}; \quad T2FD = 0$$

$$fn2 = fsys; \quad T2FD = 1$$

The schematic diagram of mode 1 and mode 3 baud rate generator is as follows:

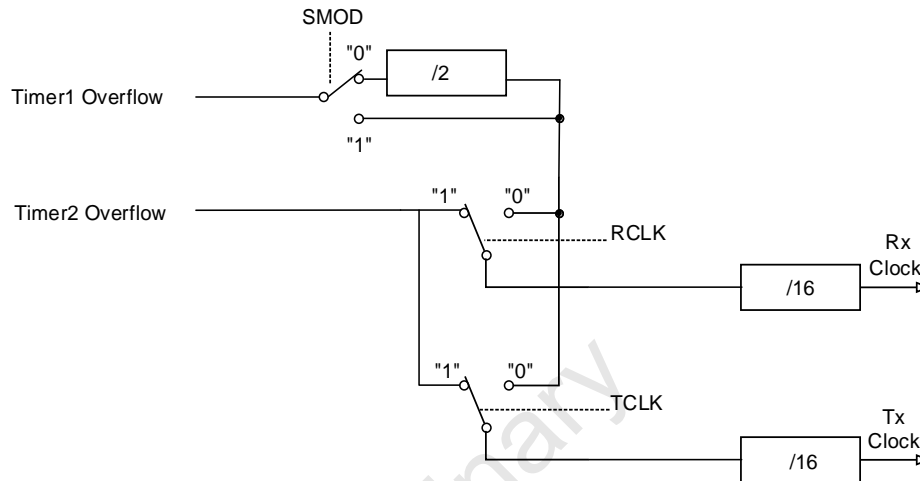

The schematic diagram of mode 1 and mode 3 baud rate generator

In mode 2, the baud rate is fixed at 1/32 or 1/64 of the system clock by the SMOD bit (PCON.7). When SMOD bit is 0, the baud rate is 1/64 of the system clock. When SMOD bit is 1, the baud rate is 1/32 of the system clock.

16 ANALOG-TO-DIGITAL CONVERTER (ADC)

The SC92F732X has a 12-bit high-precision successive approximation ADC with 11-channel, the ADC channel is multiplexing with other IO ports. Cooperating with the internal 2.4V reference voltage, one internal channel connected to 1/4 V_{DD} can be used for measuring V_{DD} voltage.

There are 2 options for ADC reference voltage:

- ① VDD pin (internal V_{DD});
- ② Precise 2.4V reference output from internal Regulator.

16.1 ADC-related Registers

ADCCON (ADH) ADC Control Register (Read/Write)

Bit Number	7	6	5	4	3	2	1	0
Bit Symbol	ADCEN	ADCS	LOWSP	EOC/ADC IF	ADCIS[3: 0]			

R/W	R/W	R/W	R/W	R/W	R/W	R/W	R/W	R/W
POR	0	0	0	0	0	0	0	n

Bit Number	Bit Symbol	Description
7	ADCEN	<p>ADC Power Control Bit</p> <p>0: Disable ADC module power</p> <p>1: Enable ADC module power</p>
6	ADCS	<p>ADC Start Trigger Control Bit (ADC Start)</p> <p>Write "1" for this bit, an ADC conversion started, this bit is the trigger signal only for ADC switch. This bit is valid only for writing "1".</p> <p>Note: After writing "1" to ADCS, do not write to the ADCCON register until the interrupt flag EOC/ADCIF is set.</p>
5	LOWSP	<p>ADC Sampling Clocks Selector:</p> <p>0: Set the clock frequency as 2MHz for ADC</p> <p>1: Set the clock frequency as 333kHz for ADC</p> <p>LOWSP controls ADC sampling clock frequency, conversion clock frequency of ADC is fixed at 2MHz, independent of the influence of LOWSP bit</p> <p>The whole process from sampling to conversion of ADC needs 6 ADC sampling clocks plus 14 ADC conversion clocks, therefore, in practical application, the total time of ADC from sampling to conversion shall be calculated as follows:</p> <p>LOWSP=0: $T_{ADC1}=6*(1/2MHz)+14*(1/2 MHz)=10us$;</p> <p>LOWSP=1: $T_{ADC2}=6*(1/333kHz)+14*(1/2 MHz)=25us$.</p>
5	EOC /ADCIF	<p>End Of Conversion / ADC Interrupt Flag</p> <p>0: Conversion not completed</p> <p>1: ADC conversion completed and need the user cleared up by software.</p> <p>ADC conversion completion flag EOC: when the user sets up ADCS for conversions, this bit will be cleared to 0 by hardware automatically; after completing conversion, this bit will be configured to 1 automatically by</p>

		hardware; ADC interrupt request flag ADCIF: this bit is also used as interrupt request flag of ADC interrupt. If ADC interrupt is enabled, this bit must be cleared by the user with software after ADC interrupt generated.
4 ~ 0	ADCIS[4: 0]	<p>ADC Input Selection Bits</p> <p>0000: Select AIN0 as ADC input</p> <p>0001: Select AIN1 as ADC input</p> <p>0010: Select AIN2 as ADC input</p> <p>0011: Select AIN3 as ADC input</p> <p>0100: Select AIN4 as ADC input</p> <p>0101: Select AIN5 as ADC input</p> <p>0110: Select AIN6 as ADC input</p> <p>0111: Select AIN7 as ADC input</p> <p>1000: Select AIN8 as ADC input</p> <p>1001: Select AIN9 as ADC input</p> <p>1010 ~ 1110: Reserved</p> <p>1111: ADC input is 1/4 V_{DD}, used for measuring power voltage</p>

ADCCFG0 (ABH) ADC Configuration Register 0 (Read/Write)

Bit Number	7	6	5	4	3	2	1	0
Bit Symbol	EAIN7	EAIN6	EAIN5	EAIN4	EAIN3	EAIN2	EAIN1	EAIN0
R/W	R/W	R/W	R/W	R/W	R/W	R/W	R/W	R/W
POR	0	0	0	0	0	0	0	0

ADCCFG1 (ACH) ADC Configuration Register 1 (Read/Write)

Bit Number	7	6	5	4	3	2	1	0
Bit Symbol	-	-	-	-	-	-	EAIN9	EAIN8
R/W	-	-	-	-	-	-	R/W	R/W

POR	x	x	x	x	x	x	0	0
-----	---	---	---	---	---	---	---	---

Bit Number	Bit Symbol	Description
0	EAINx (x=0 ~ 9)	ADC Port Configuration Register 0: Configure AINx as IO PORT 1: Configure AINx as ADC input and remove pull-up resistance automatically.

OP_CTM1 (C2H@FFH) Customer Option Register 1 (Read/Write)

Bit Number	7	6	5	4	3	2	1	0
Bit Symbol	VREFS	-	-	-	IAPS[1: 0]		-	-
R/W	R/W	-	-	-	R/W	R/W	-	-
POR	n	x	x	x	n	n	x	x

Bit Number	Bit Symbol	Description
7	VREFS	Reference Voltage Selection Bit (Default values are configured by the user and loaded from Code Option) 0: Configure ADC VREF as V _{DD} 1: Configure ADC VREF as internal correct 2.4 V

ADCVL (AEH) ADC Conversion Value Register (Low Bit) (Read/Write)

Bit Number	7	6	5	4	3	2	1	0
Bit Symbol	ADCV[3: 0]				-	-	-	-
R/W	R/W	R/W	R/W	R/W	-	-	-	-

POR	0	0	0	0	x	x	x	x
-----	---	---	---	---	---	---	---	---

ADCVH (AFH) ADC Conversion Value Register (High Bit) (Read/Write)

Bit Number	7	6	5	4	3	2	1	0
Bit Symbol	ADCV[11: 4]							
R/W	R/W	R/W	R/W	R/W	R/W	R/W	R/W	R/W
POR	0	0	0	0	0	0	0	0

Bit Number	Bit Symbol	Description
11 ~ 4	ADCV[11: 4]	ADC conversion value high byte values
3 ~ 0	ADCV[3: 0]	ADC conversion value low 4-bit values

IE (A8H) Interrupt Enable Register (Read/Write)

Bit Number	7	6	5	4	3	2	1	0
Bit Symbol	EA	EADC	ET2	EUART	ET1	EINT1	ET0	EINT0
R/W	R/W	R/W	R/W	R/W	R/W	R/W	R/W	R/W
POR	0	0	0	0	0	0	0	0

Bit Number	Bit Symbol	Description
6	EADC	ADC Interrupt Enable Control Bit 0: EOC/ADCIF interrupt not allowed 1: EOC/ADCIF interrupt allowed

IP (B8H) Interrupt Priority Control Register (Read/Write)

Bit Number	7	6	5	4	3	2	1	0
Bit Symbol	-	IPADC	IPT2	IPUART	IPT1	IPINT1	IPT0	IPINT0
R/W	-	R/W	R/W	R/W	R/W	R/W	R/W	R/W
POR	x	0	0	x	0	0	0	0

Bit Number	Bit Symbol	Description
6	IPADC	ADC Interruption Priority Selection Bit 0: Set the interrupt priority of ADC to be "low" 1: Set the interrupt priority of ADC to be "high"

16.2 ADC Conversion Steps

Operating steps for the user to practically conduct ADC conversion are shown below:

- ① Configure ADC input pin; (configure corresponding bit of AINx as ADC input, in general, ADC pin will be prefixed);
- ② Configure ADC reference voltage Vref and ADC conversion frequency;
- ③ Enable ADC;
- ④ Select ADC input channel; (Configure ADCIS bit and select ADC input channel);
- ⑤ Enable ADCS, and start conversion;
- ⑥ Wait for EOC/ADCIF=1, if ADC interrupt is enabled, ADC interrupt will be generated and the user shall clear EOC/ADCIF flag to 0 by software;
- ⑦ Obtain 12-bit data from ADCVH, ADCVL from high bit to low bit, and complete a conversion
- ⑧ If no change in input channel, repeat Step 5 to Step 7 for next conversion.

Note: Before setting up IE[6] (EADC), it is recommended for the user to use software to clear the EOC/ADCIF flag first. After completing ADC interrupt service process, user shall eliminate EOC/ADCIF to avoid generating ADC interrupt constantly.

17 EEPROM AND IAP OPERATIONS

EEPROM and IAP operating modes are shown below:

1. 128 bytes EEPROM can be used as data storage;
2. The Code area of IC and 128 bytes of EEPROM can be used for IAP operations, which is mainly used for remote program updating.

As Code Option, the user shall select EEPROM and IAP operating space before it is written to IC by programmer:

OP_CTM1 (C2H@FFH) Customer Option Register 1 (Read/Write)

Bit number	7	6	5	4	3	2	1	0
Bit symbol	VREFS	-	-	-	IAPS[1: 0]		-	-
R/W	R/W	-	-	-	R/W	R/W	-	-
POR	n	x	x	x	n	n	x	x

Bits	Name	Description
3 ~ 2	IAPS[1: 0]	<p>IAP Space Scope Selection Bits</p> <p>00: Code area prohibits IAP operations, only EEPROM area used for data storage</p> <p>01: Last 0.5k code area allows IAP operation (1E00H ~ 1FFFH)</p> <p>10: Last 1k code area allows IAP operation (1C00H ~ 1FFFH)</p> <p>11: All code area allows IAP operation (0000H ~ 1FFFH)</p>

17.1 EEPROM / IAP Operating-related Registers

Description for EEPROM / IAP operating-related registers:

Symbol	Address	Description	7	6	5	4	3	2	1	0	Reset value
IAPKEY	F1H	IAP Protection Register	IAPKEY[7: 0]								0000000b

IAPADL	F2H	IAP Write Address Low Register	IAPADR[7: 0]					00000000b
IAPADH	F3H	IAP Write Address High Register	-	-	-	IAPADR[12: 8]		xxx00000b
IAPADE	F4H	IAP Write Extended Address Register	IAPADER[7: 0]					00000000b
IAPDAT	F5H	IAP Data Register	IAPDAT[7: 0]					00000000b
IAPCTL	F6H	IAP Control Register	-	-	-	-	PAYTIMES [1: 0]	CMD[1: 0] xxxx0000b

IAPKEY (F1H) IAP Protection Register (Read/Write)

Bit Number	7	6	5	4	3	2	1	0
Bit Symbol	IAPKEY[7: 0]							
R/W	R/W	R/W	R/W	R/W	R/W	R/W	R/W	R/W
POR	0	0	0	0	0	0	0	0

Bit Number	Bit symbol	Description
7 ~ 0	IAPKEY[7: 0]	Enable EEPROM/IAP function and operation time limit configuration Write a non-zero value n, representing: <ol style="list-style-type: none"> ① Enable EEPROM / IAP function; ② If no writing command is received after n system clocks, EEPROM / IAP function will be reclosed.

IAPADL (F2H) IAP Write Address Low Register (Read/Write)

Bit Number	7	6	5	4	3	2	1	0
Bit Symbol	IAPADR[7: 0]							
R/W	R/W	R/W	R/W	R/W	R/W	R/W	R/W	R/W
POR	0	0	0	0	0	0	0	0

Bit Number	Bit symbol	Description
7 ~ 0	IAPADR[7: 0]	EEPROM/IAP writing address low byte

IAPADH (F3H) IAP Write Address High Register (Read/Write)

Bit Number	7	6	5	4	3	2	1	0
Bit Symbol	-	-	-	IAPADR[12: 8]				
R/W	-	-	-	R/W	R/W	R/W	R/W	R/W
POR	x	x	x	0	0	0	0	0

Bit Number	Bit symbol	Description
4 ~ 0	IAPADR[12: 8]	EEPROM/IAP writing address high 5-bit
7 ~ 5	-	Reserved

IAPADE (F4H) IAP Write Extended Address Register (Read/Write)

Bit Number	7	6	5	4	3	2	1	0
Bit Symbol	IAPADER[7: 0]							

R/W	R/W	R/W	R/W	R/W	R/W	R/W	R/W	R/W
POR	0	0	0	0	0	0	0	0

Bit Number	Bit symbol	Description
7 ~ 0	IAPADER[7: 0]	IAP Extended Address: 0x00: MOVC and IAP programming for Code 0x01: Conduct reading operation for user ID region, no writing operation is allowed 0x02: MOVC and IAP programming for EEPROM Other: Reserved

IAPDAT (F5H) IAP Data Register (Read/Write)

Bit Number	7	6	5	4	3	2	1	0
Bit Symbol	IAPDAT[7: 0]							
R/W	R/W	R/W	R/W	R/W	R/W	R/W	R/W	R/W
POR	0	0	0	0	0	0	0	0

Bit Number	Bit symbol	Description
7 ~ 0	IAPDAT	Data written by EEPROM/IAP

IAPCTL (F6H) IAP Control Register (Read/Write)

Bit Number	7	6	5	4	3	2	1	0
Bit Symbol	-	-	-	-	PAYTIMES[1: 0]		CMD[1: 0]	
R/W	-	-	-	-	R/W	R/W	R/W	R/W

POR	x	x	x	x	0	0	0	0
-----	---	---	---	---	---	---	---	---

Bit Number	Bit symbol	Description
3 ~ 2	PAYTIMES[1: 0]	<p>Upon EEPROM/IAP writing operation, CPU Hold Time length configuration</p> <p>00: Configure CPU HOLD TIME 4mS@24/12/6/2 MHz</p> <p>01: Configure CPU HOLD TIME 2mS@24/12/6/2 MHz</p> <p>10: Configure CPU HOLD TIME 1mS@24/12/6/2 MHz</p> <p>11: Reserved</p> <p>Notes: The CPU Hold is for PC pointer, other functional module continues to work; interrupt flag is saved, and interrupt is generated after completing Hold, but several times of interrupt can only be saved once.</p> <p>Recommended Selection: 2.7V ~ 5.5 V for V_{DD}, 10 is available</p> <p>2.4V ~ 5.5V for V_{DD}, 01 or 00 is available</p>
1 ~ 0	CMD[1: 0]	<p>EEPROM / IAP writing operating command</p> <p>10: Write</p> <p>Other: Reserved</p> <p>Note: The statement of EEPROM/IAP write operation shall be followed by at least 4 NOP instructions to guarantee subsequent instruction can be implemented normally after finishing IAP operation!</p>

17.2 EEPROM / IAP Operating Procedures:

Writing procedure of the SC92F732X EEPROM/IAP are shown below:

- ① Write 0x00 into IAPADE[7: 0]: select Code Area and conduct IAP operation; write 0x02 into IAPADE[7: 0]: select EEPROM and conduct EEPROM reading and writing operations;
- ② Write data into IAPDAT[7: 0] (data for EEPROM / IAP writing ready);
- ③ Write address into {IAPADR[12: 8], IAPADR[7: 0]} (target address of EEPROM/IAP operation ready);
- ④ Write a nonzero value n into IAPKEY[7: 0] (switch on protection of EEPROM / IAP, and EEPROM / IAP function will be switched off when there is no writing command within n system clocks);
- ⑤ Write CPU Hold time into IAPCTL[3: 0] (configure CPU Hold time by setting CMD[1: 0] to 1 or 0, CPU is Hold up and start up EEPROM/IAP writing);

- ⑥ EEPROM/IAP writing ends, CPU proceeds to subsequent operations.

Notes:

1. When programming IC, if “Code Area Prohibits IAP Operations” is selected by Code Option, IAP is unavailable upon IAPADE[7: 0]=0x00 (Select Code Area), meaning it is unable to write data, and such data can only be read by MOVC command.
2. When IAPADE=0x01 or 0x02, MOVC instruction and writing operation are conducted in EEPROM or IFB area. If any interrupt occurs and there are also MOVC operations in this interrupt, it may result in error of MOVC operations and thus abnormal operation of program. To avoid such situation, the user shall disable global interrupt control bit (EA=0) before conducting IAPADE=0x01 or 0x02 operations. After operation completed, configure IAPADE =0x00 and enable global interrupt control bit (EA=1).

17.2.1 128 BYTES INDEPENDENT EEPROM OPERATING DEMO PROGRAMME

```
#include "intrins.h"

unsigned char EE_Add;

unsigned char EE_Data;

unsigned char code * POINT =0x0000;
```

C Demo Program of EEPROM Write Operation:

```
EA = 0; // Disable global Interrupt

IAPADE = 0x02; //Select EEPROM Area

IAPDAT = EE_Data; //Transmit data to EEPROM data register

IAPADH = 0x00; //High-bit address default write 0x00

IAPADL = EE_Add; //Write EEPROM target address low bit

IAPKEY = 0xF0; //This value can be adjusted as required: it shall guarantee that

// The time interval between this instruction implemented and writing
IAPCTL value shall be less than 240 (0xf0) system clocks, or else, IAP function
is closed;

//Pay special attention to enabling interrupt;

IAPCTL = 0x0A; //Implement EEPROM write operation, 1ms@24/12/6/2 MHz;

_nop_ (); //Wait (at least 4 _nop_ ())

_nop_ ();

_nop_ ();

_nop_ ();

IAPADE = 0x00; //Return to ROM Area

EA = 1; //Enable master interrupt
```

C Demo Program of EEPROM Read Operation

```
EA = 0;                //Disable master interrupt
IAPADE = 0x02;        //Select EEPROM Area
EE_Data = * ( POINT +EE_Add);    //Read value in IAP_Add to IAP_Data
IAPADE = 0x00;        //Return to ROM Area , prevent MOVC operates to EEPROM
EA = 1;                // Enable global interrupt
```

17.2.2 CODE MEMORY IAP OPERATING DEMO PROGRAMME

```
#include "intrins.h"
unsigned int IAP_Add;
unsigned char IAP_Data;
unsigned char code * POINT =0x0000;
```

C Demo Program of IAP Write Operation:

```
IAPADE = 0x00;        //Select Code Area
IAPDAT = IAP_Data;    //Transmit data to IAP data register
IAPADH = (unsigned char) ( (IAP_Add >> 8)); //Write IAP target address high bit
IAPADL = (unsigned char)IAP_Add;           //Write IAP target address low bit
IAPKEY = 0xF0;        //This value can be adjusted as required; it shall guarantee this
//instruction is implemented to assigned IAPTL value;
// Time interval shall be less than 240 (0xf0) system clocks, or
// else, IAP function is closed;
//Pay special attention upon starting interrupt
IAPCTL = 0x0A;        //Implement EEPROM write operation, 1ms@24/12/6/2MHz;
_nop_ ();            //Wait (at least 4 _nop_ ())
_nop_ ();
_nop_ ();
_nop_ ();
```

C Demo Program of IAP Read Operation:

```
IAPADE = 0x00;        //Select Code Area
IAP_Data = * ( POINT+IAP_Add);    //Read value in IAP_Add to IAP_Data
```

Misoperation may result in the user programme to be rewritten! Unless such function is required by the user (such as used for remote programme update, etc.), it is not recommended to used by the user.

Preliminary

18 ELECTRICAL CHARACTERISTICS

18.1 absolute maximum ratings

Symbol	Parameter	Min Value	Max Value	Unit
V _{DD} /V _{SS}	DC supply voltage	-0.3	5.5	V
Voltage ON any Pin	Input / Output voltage of any pin	-0.3	V _{DD} +0.3	V
T _A	Ambient temperature	-40	85	°C
T _{STG}	Storage temperature	-55	125	°C

18.2 Recommended Operating Conditions

Symbol	Parameter	Min Value	Max Value	Unit	System Clock Frequency
V _{DD1}	Operating voltage	3.7	5.5	V	>16MHz
V _{DD2}	Operating voltage	2.4	5.5	V	≤16MHz
T _A	Ambient temperature	-40	85	°C	-

18.3 D.C. Characteristics

(V_{DD} = 5V, T_A = +25°C, unless otherwise specified)

Symbol	Parameter	Min Value	Typical Value	Max Value	Unit	Testing Conditions
Current						
I _{op1}	Operating current	-	10	-	mA	f _{sys} =24MHz
I _{op2}	Operating current	-	7.3	-	mA	f _{sys} =12MHz

I _{op3}	Operating current	-	6	-	mA	f _{sys} =6MHz
I _{op4}	Operating current	-	5	-	mA	f _{sys} =2MHz
I _{pd1}	Standby Current (Power Down Mode)	-	0.7	1.0	μA	
I _{IDL1}	Standby Current (IDLE Mode)	-	6.5	8	mA	
I _{BTM}	Base Timer Operating Current	-	6	10	μA	BTMFS[2: 0]= 111 One interrupt occurs for every 2.0 seconds
I _{WDT}	WDT Current	-	1	3	μA	WDTCKS[2: 0]= 000 WDT overflows every 500ms
I/O Port Features						
V _{IH1}	Input high voltage	0.7V _{DD}	-	V _{DD} +0.3	V	
V _{IL1}	Input low voltage	-0.3	-	0.3V _{DD}	V	
V _{IH2}	Input high voltage	0.8V _{DD}	-	V _{DD}	V	Schmidt trigger input:
V _{IL2}	Input low voltage	-0.2	-	0.2V _{DD}	V	RST/tCK/SCK
I _{oL1}	Output low current	-	35	-	mA	V _{Pin} =0.4V
I _{oL2}	Output low current	-	70	-	mA	V _{Pin} =0.8V
I _{oH1}	Output high current P1/P5	-	22	-	mA	V _{Pin} =4.3V
I _{oH2}	Output high current	-	13	-	mA	V _{Pin} =4.7V

	P1/P5					
I _{OH3}	Output high current P0/P2	-	22	-	mA	V _{Pin} =4.3V P _{xyz} = 0, I _{OH} level 0
	Output high current P0/P2	-	16	-	mA	V _{Pin} =4.3V P _{xyz} = 1, I _{OH} level 1
	Output high current P0/P2	-	13	-	mA	V _{Pin} =4.3V P _{xyz} = 2, I _{OH} level 2
	Output high current P0/P20	-	9	-	mA	V _{Pin} =4.3V P _{xyz} = 3, I _{OH} level 3
I _{OH4}	Output high current P0/P2	-	13	-	mA	V _{Pin} =4.7V P _{xyz} = 0, I _{OH} level 0
	Output high current P0/P2	-	10	-	mA	V _{Pin} =4.7V P _{xyz} = 1, I _{OH} level 1
	Output high current P0/P2	-	7	-	mA	V _{Pin} =4.7V P _{xyz} = 2, I _{OH} level 2
	Output high current P0/P20	-	5	-	mA	V _{Pin} =4.7V P _{xyz} = 3, I _{OH} level 3
R _{PH1}	Pull-up resistance	-	30	-	kΩ	
Internal calibrated 2.4V as ADC reference voltage						
V _{DD24}	Internal reference 2.4V voltage output	2.37	2.40	2.45	V	T _A =-40 ~ 85°C

($V_{DD} = 3.3V$, $T_A = +25^{\circ}C$, unless otherwise specified)

Symbol	Parameter	Min Value	Typical Value	Max Value	Unit	Conditions
Current						
I_{op5}	Operating current	-	7.0	-	mA	$f_{SYS} = 24MHz$
I_{op6}	Operating current	-	5.0	-	mA	$f_{SYS} = 12MHz$
I_{op7}	Operating current	-	4.2	-	mA	$f_{SYS} = 6MHz$
I_{op8}	Operating current	-	3.6	-	mA	$f_{SYS} = 2MHz$
I_{pd2}	Standby Current (Power Down Mode)	-	0.6	1.0	uA	
I_{IDL2}	Standby Current (IDLE Mode)	-	4.4	6	mA	
I/O Port Features						
V_{IH3}	Input high voltage	$0.7V_{DD}$	-	$V_{DD}+0.3$	V	
V_{IL3}	Input low voltage	-0.3	-	$0.3V_{DD}$	V	
V_{IH4}	Input high voltage	$0.8V_{DD}$	-	V_{DD}	V	Schmidt trigger input:
V_{IL4}	Input low voltage	-0.2	-	$0.2V_{DD}$	V	RST/tCK/SCK
I_{OL3}	Output low current	-	25	-	mA	$V_{Pin} = 0.4V$
I_{OL4}	Output low current	-	47	-	mA	$V_{Pin} = 0.8V$
I_{OH5}	Output high current $P_{xyz} = 0$	-	7	-	mA	$V_{Pin} = 3.0V$
R_{PH2}	Pull-up resistance	-	55	-	k Ω	

Internal calibrated 2.4V as ADC reference voltage						
V_{DD24}	Internal reference 2.4V voltage output	2.37	2.40	2.45	V	$T_A = -40 \sim 85^\circ\text{C}$

18.4 AC Electrical features

($V_{DD} = 2.4\text{V} \sim 5.5\text{V}$, $T_A = 25^\circ\text{C}$, unless otherwise specified)

Symbol	Parameter	Min	Typical	Max	Unit	Conditions
T_{OSC}	External 32kHz oscillator start-up time	-	-	1	s	External 32KHz crystal oscillator
T_{POR}	Power On Reset time	-	5	10	ms	
T_{PDW}	Power Down Mode waking-up time	-	5	10	ms	
T_{Reset}	Reset Pulse Width	18	-	-	μs	Valid for Low level
f_{HRC}	RC oscillation stability	23.76	24	24.24	MHz	$V_{DD} = 4.5 \sim 5.5\text{V}$ $T_A = -20 \sim 85^\circ\text{C}$

18.5 ADC Electrical Features

($T_A = 25^\circ\text{C}$, unless otherwise specified)

Symbol	Parameter	Min	Typical	Max	Unit	Conditions
V_{AD}	Supply Voltage	3.0	5.0	5.5	V	
N_R	Precision	-	12	-	bit	$GND \leq V_{AIN} \leq V_{DD}$
V_{AIN}	ADC Input Voltage	GND	-	V_{DD}	V	

R _{AIN}	ADC input resistance	1	-		MΩ	V _{IN} =5V
I _{ADC1}	ADC conversion current 1	-	-	2	mA	ADC Module on V _{DD} =5V
I _{ADC2}	ADC conversion current 2	-	-	1.8	mA	ADC module on V _{DD} =3.3V
DNL	Differential nonlinear error	-	±1	-	LSB	V _{DD} =5V V _{REF} =5V
INL	Integral nonlinear error	-	±1	-	LSB	
E _Z	Offset error	-	±8	-	LSB	
E _F	Full scale error	-	±10	-	LSB	
E _{AD}	Total absolute error	-	±10	-	LSB	
T _{ADC1}	ADC conversion time 1	-	10	-	μs	ADC Clock = 2MHz
T _{ADC2}	ADC conversion time 2	-	25	-	μs	ADC Clock = 333kHz

19 ORDERING INFORMATION

PRODUCT NO	PKG	PACKING
SC92F7323M28U	SOP28L	TUBE
SC92F7323X28U	TSSOP28L	TUBE
SC92F7322M20U	SOP20L	TUBE
SC92F7322X20U	TSSOP20L	TUBE
SC92F7322Q20R	QFN20L	TRAY
SC92F7321M16U	SOP16L	TUBE
SC92F7320M08U	SOP8L	TUBE

Preliminary

20 PACKAGEING INFORMATION

SC92F7323M28U

SOP28L (300mil) Dimension

Unit: mm

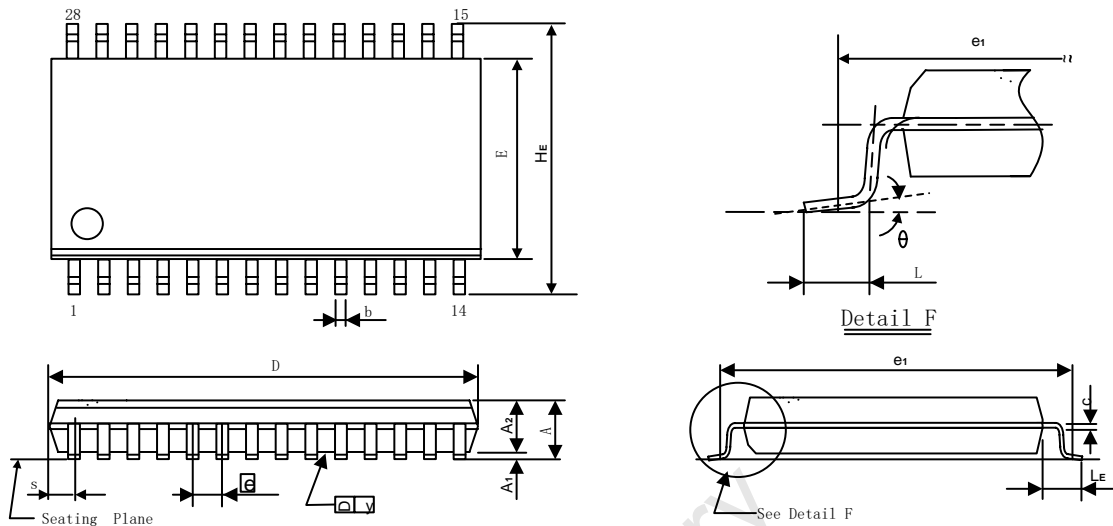

Symbol	mm (milimetre)		
	Min	Normal	Max
A	2.465	2.515	2.565
A1	0.100	0.150	0.200
A2	2.100	2.300	2.500
b	0.356	0.406	0.456
C	0.254 (BSC)		
D	17.750	17.950	18.150
E	7.374	7.450	7.574
HE	10.100	10.300	10.500

e	1.270 (BSC)		
L	0.764	0.864	0.964
LE	1.303	1.403	1.503
θ	0°	-	10°
S	0.745 (BSC)		

Preliminary

SC92F7323X28U

TSSOP28 Dimension

Unit: mm

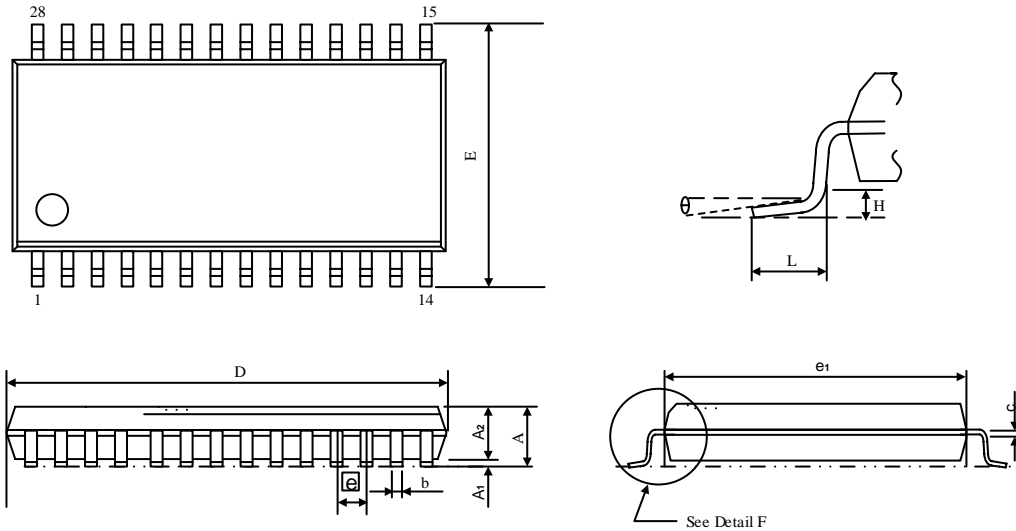

Symbol	mm (millimetre)		
	Min	Normal	Max
A	-	-	1.200
A1	0.050	-	0.150
A2	0.800	-	1.000
b	0.190	-	0.300
c	0.090	-	0.200
D	9.600	-	9.800
E	6.250	-	6.550
e1	4.300	-	4.500
e	0.65 (BSC)		

L	0.500	-	0.700
θ	1°	-	7°
H	0.25 (TYP)		

Preliminary

SC92F7322Q20R

QFN20(4X4) Dimension Unit: mm

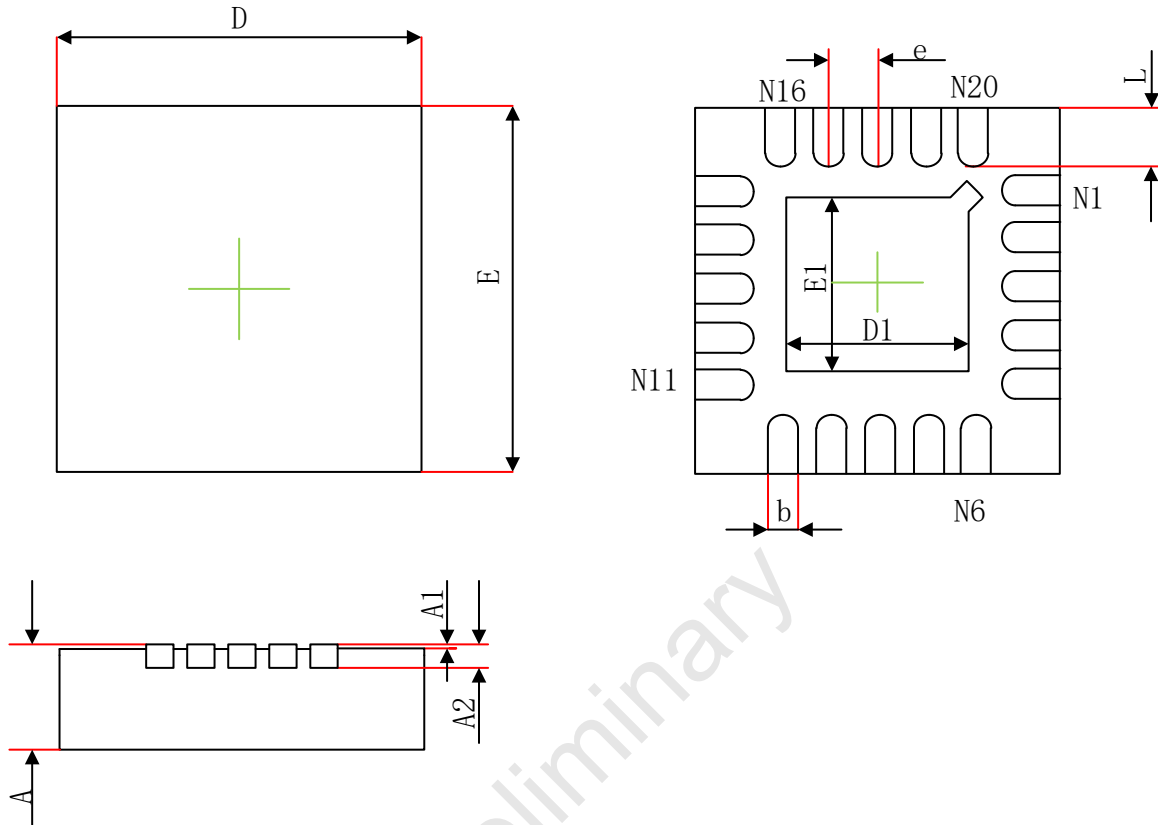

Symbol	mm (milimetre)		
	Min	Normal	Max
A	0.700/0.800	0.750/0.850	0.800/0.900
A1	0	-	0.050
A2	0.153	0.203	0.253
b	0.180	0.250	0.300
D	3.900	4.000	4.100
D1	1.900	2.000	2.100

E	3.900	4.000	4.100
E1	1.900	2.000	2.100
e	0.450	0.500	0.550
L	0.390	0.400	0.410

Preliminary

SC92F7322M20U

SOP20L(300mil) Dimension Unit: mm

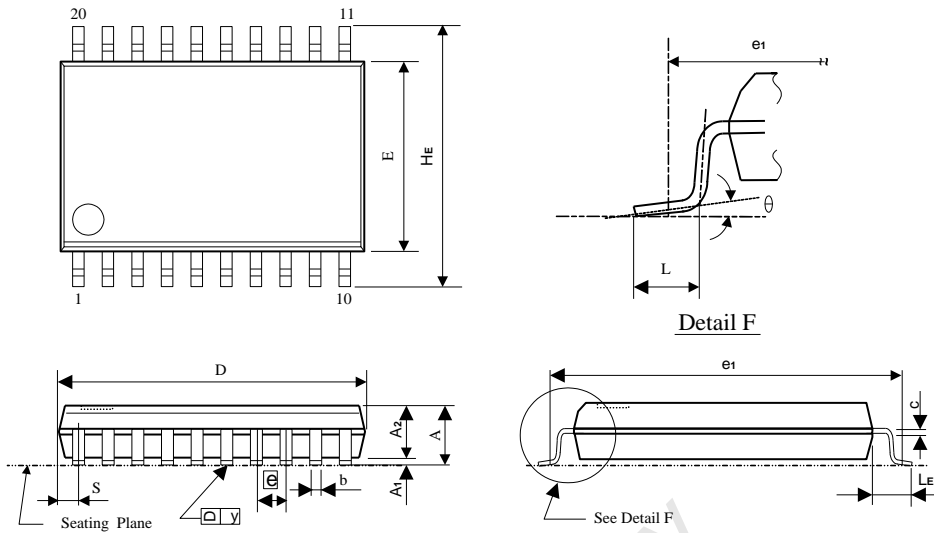

Symbol	mm (millimetre)		
	Min	Normal	Max
A	2.465	2.515	2.565
A1	0.100	0.150	0.200
A2	2.100	2.300	2.500
b	0.356	0.406	0.456
C	0.254(BSC)		
D	12.500	12.700	12.900
E	7.400	7.450	7.500
HE	10.206	10.306	10.406

e	1.27(BSC)		
L	0.800	0.864	0.900
LE	1.303	1.403	1.503
θ	0°	-	10°
S	0.660(BSC)		

Preliminary

SC92F7322X20U

TSSOP20L Dimension Unit: mm

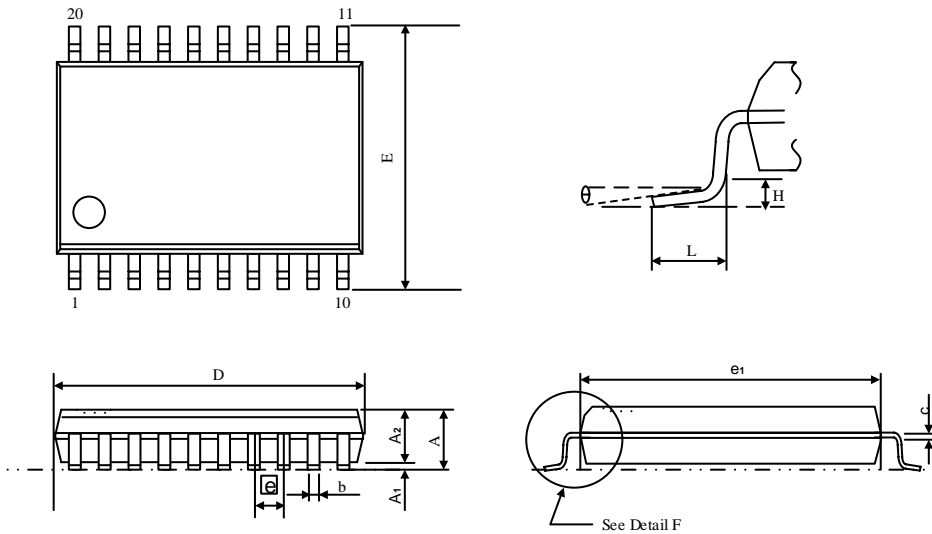

Symbol	mm (milimetre)		
	Min	Normal	Max
A	-	-	1.200
A1	0.050	-	0.150
A2	0.800	-	1.000
b	0.190	-	0.300
c	0.090	-	0.200
D	6.400	-	6.600
E	6.250	-	6.550
e1	4.300	-	4.500
e	0.65(BSC)		

L	0.500	-	0.700
θ	1°	-	7°
H	0.25(TYP)		

Preliminary

SC92F7321M16U

SOP16L(150mil) Dimension Unit: mm

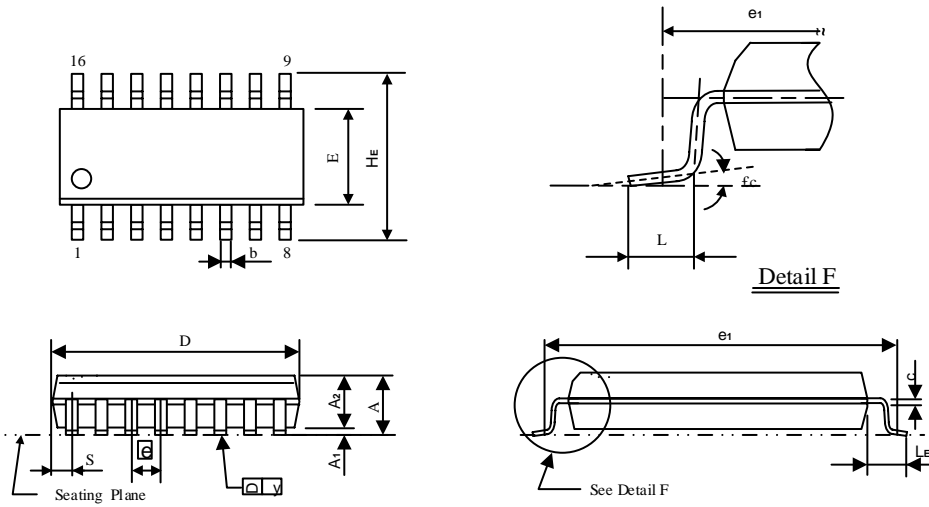

Symbol	mm (milimetre)		
	Min	Normal	Max
A	1.500	1.600	1.700
A1	0.100	0.150	0.200
A2	1.400	1.450	1.500
b	0.356	0.406	0.470
C	0.203(BSC)		
D	9.700	9.900	10.160
S	0.505(BSC)		
E	3.800	3.900	4.000
HE	5.900	6.000	6.100
e	1.27(BSC)		

L	0.500	0.660	0.700
LE	0.950	1.050	1.150
θ	0°	-	8°

Preliminary

SC92F7320M08U

SOP8L(150mil) Dimension Unit: mm

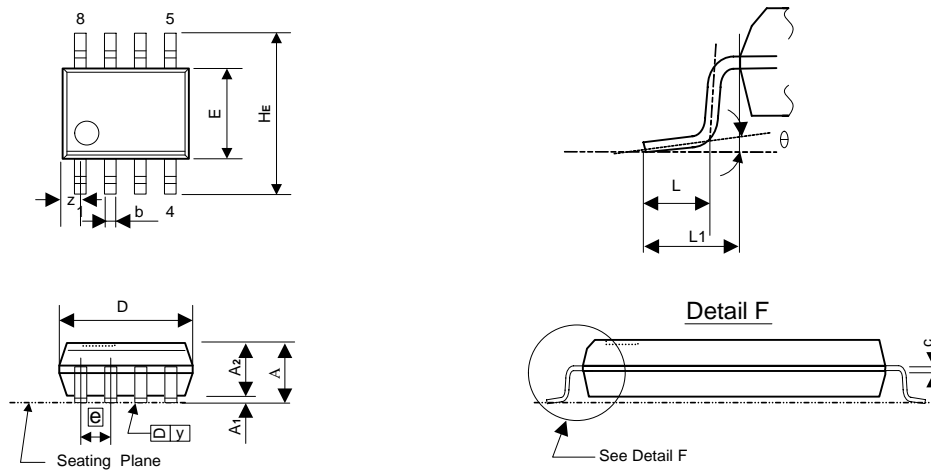

Symbol	mm (milimetre)		
	Min	Normal	Max
A	1.450	1.600	1.700
A1	0.100	0.150	0.200
A2	-	1.450	-
b	0.356	0.406	0.510
C	0.143	0.203	0.263
D	4.700	4.900	5.100
E	3.810	3.860	3.950
HE	5.850	6.000	6.150
e	1.270(BSC)		
L	0.450	0.600	0.750
L1	0.950	1.050	1.150

θ	0°	-	10°
----------	----	---	-----

Preliminary

21 REVISION HISTORY

Version	Notes	Date
V0.2	Update SOP8L Dimension	March 2020
V0.1	Initial Release.	September 2019

Preliminary